

## Lab 3 – STFT (a.k.a. instantaneous spectrum)

Questions marked like this are obligatory to be answered in your report. You should use your own wisdom whether to include more explanations, sketches etc. to document your work.

*Italic items are optional. Do them if you have time. Document them in the report and discuss with the teacher.*

1. Simulate a signal containing 400 samples: 200 samples of a sinusoid with  $\theta_1 = 0.24\pi$  (for  $n = 0 \dots 199$ ) and 200 samples of a sinusoid with  $\theta_2 = 0.72\pi$  (for  $n = 200 \dots 399$ ).

```
x1=sin(0.24*pi*[0:199]);  
x2=sin(0.72*pi*[200:399]);  
x=[x1 x2];
```

- (a) Plot the signal. Plot its magnitude spectrum (**NOT** an STFT) with boxcar window using log scale, limit the plot at -40 dB. Make a sketch of the spectrum

**Hint:**

- “Magnitude spectrum” (or “Amplitude spectrum”) is a short way of saying “absolute value of Fourier transform”. Practically, you need to:
    - multiply signal `.*` with window (if using window)
    - calculate FFT of your signal
    - calculate absolute value `abs()`
  - Logarithmic scale in electronics is usually marked with decibels. A value in decibels is  $10 \cdot \log_{10}$  from ratio of powers (or  $20 \cdot \log_{10}$  from ratio of amplitudes). Without a reference power (to calculate ratio), we typically use 1 as reference – e.g. `X_db=20*log10(abs(X))`.
  - A simple trick to limit the vertical scale at `y_min` is to `plot(max(y,y_min))`; another way is to use `axis()` command (`help axis`) or to use the plot GUI (not so easy!).
- (b) *Plot the amplitude spectrum computed with Hamming window (Matlab: `hamming(L)` where  $L$  is the window length). What is the difference between your plots with boxcar and hamming?*
  - (c) Reverse the order of frequencies in your signal (0.72 in the first half, 0.24 in the second), and plot the spectrum. Compare with previous plots. Can you tell anything about the properties of signal changing vs. time from this spectrum?

- (d) Compute FFT with sliding window:

```
swifft(x,g,n); % if swifft does not work, use c3_swifft where  
n - vector of window locations (endpoints) – use 1:500;  
g - a window (hamming(100))  
x - the signal
```

Press space to see the movie.

- (e) Plot the spectrogram `spectrogram(x,hamming(100),90);`, (the third parameter says to move window by  $100 - 90 = 10$  samples). Note the transitions between segments with different frequencies. Describe the shape of the spectrum at the transition between segments
2. Repeat 1e for shorter window. Describe the differences between plot with different window length.
  3. Plot the spectrogram of an LFM (linear frequency modulation) signal from the generator: pull the “sweep width” handle to switch the modulation on, see the signal on the oscilloscope, choose the frequencies and sweep width to obtain a nice plot of  $N = 1024$  samples; for gathering the data use `y=GETDATA(N,1,Ts)` command. Sketch the spectrogram e.g. using contour lines. Mark physical time and physical frequencies on your sketch.

Connections:

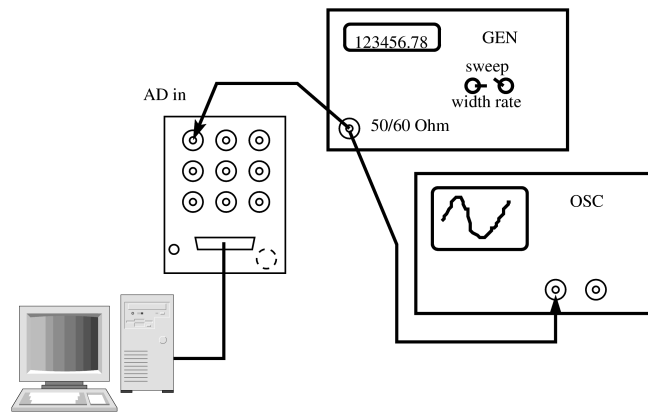

**Hint:**

- set “width” about 3 o’clock, “speed” about 10 o’clock; verify your signal with an oscilloscope; if any doubt, record the signal and show the recording to the teacher
  - An LFM signal is a signal whose frequency changes in a “sawtooth” manner – usually rising slowly from  $f_{min}$  to  $f_{max}$ , then dropping back to  $f_{min}$  and so on. You should set the generator so that your recorded signal encompasses 1 or two such cycles.
  - Contour lines show the surface in the manner used in cartography (a physical map).
4. Experiment to see the properties of different window lengths (at least 2 lengths) and window types (2-4 types, maybe including Kaiser with different  $\beta$ ; `help window` to see how many window types are defined in Matlab). Sketch most interesting results; describe differences between results with different window lengths and types. Try to understand signal components visible on the spectrogram.
  5. *Repeat the two previous experiments with modulated triangle wave. (sketch only the most important picture)*
  6. Plot the spectrogram of a voice signal from the microphone: use the preamplifier (middle row on an A/D input card; adjust the amplification with a red switch and black knob to have A/D input inside  $\pm 2V$  range), gather 8000 samples, think before choosing  $f_s$ . Try to see some features of different sounds. Try to match a good window to signal properties. Sketch a chosen interesting part (with contour lines); try to note what sound it was

Connections:

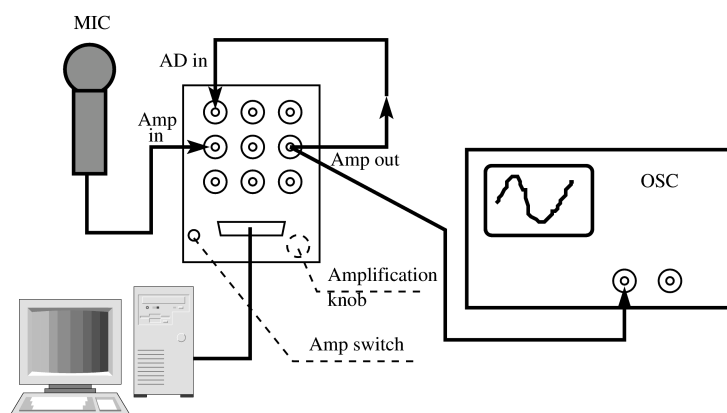

Note: `swift` is not a standard Matlab function. It has been written for this lab.

File: lab03 L<sup>A</sup>T<sub>E</sub>Xed on April 8, 2015