

DAB

Digital Audio Broadcasting

DAB history

DAB has been under development since 1981 at the [Institut für Rundfunktechnik](#) (IRT).

In 1985 the first DAB demonstrations were held at the WARC-ORB in Geneva and in 1988 the first DAB transmissions were made in Germany.

Later DAB (or Eureka-147) was developed as a research project for the [European Union](#) (Eureka project number EU147), which started in 1987 on initiative by a consortium formed in 1986. The [MP2](#) (MPEG-1 layer-2) audio coding technique was created as part of the EU147 project. DAB was the first standard based on [orthogonal frequency division multiplexing](#) (OFDM) modulation technique, which since then has become one of the most popular transmission schemes for modern wideband digital communication systems.

A choice of audio codec, modulation and error-correction coding schemes and first trial broadcasts were made in 1990. Public demonstrations were made in 1993 in the [United Kingdom](#). The protocol specification was finalized in 1993 and adopted by the [ITU-R](#) standardization body in 1994, the European community in 1995 and by [ETSI](#) in 1997. Pilot broadcasts were launched in several countries in 1995.

The UK was the first country to receive a wide range of [radio stations](#) via DAB. Commercial DAB receivers began to be sold in 1999 and over 50 commercial and [BBC](#) services were available in London by 2001. The UK has to date been the most successful market for DAB and is being projected to be in 40% of homes by 2009.^[5]

By 2006, 500 million people worldwide were in the coverage area of DAB broadcasts, although by this time sales had only taken off in the [UK](#) and [Denmark](#). In 2006 there are approximately 1,000 DAB stations in operation world wide.^[6]

You will see in Figure 1 how each service signal is coded individually at source level, error protected and time interleaved in the channel coder. Then the services are multiplexed in the Main Service Channel (MSC), according to a pre-determined, but adjustable, multiplex configuration. The multiplexer output is combined with Multiplex Control and Service information, which travel in the fast Information Channel (FIC), to form the transmission frames in the Transmission Multiplexer. FIG 1 Finally, Orthogonal Frequency Division Multiplexing (OFDM) is applied to shape the DAB signal, which consists of a large number of carriers. The signal is then transposed to t

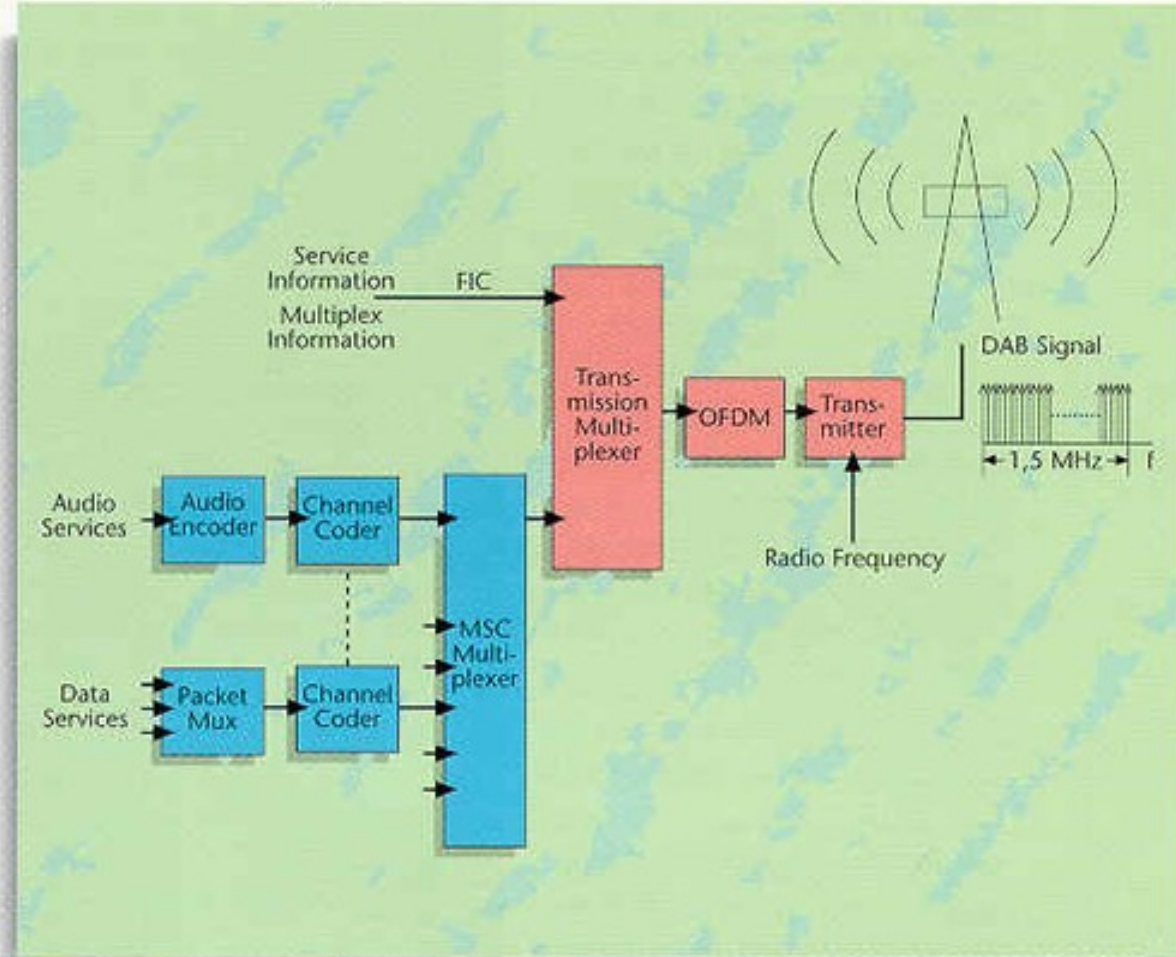
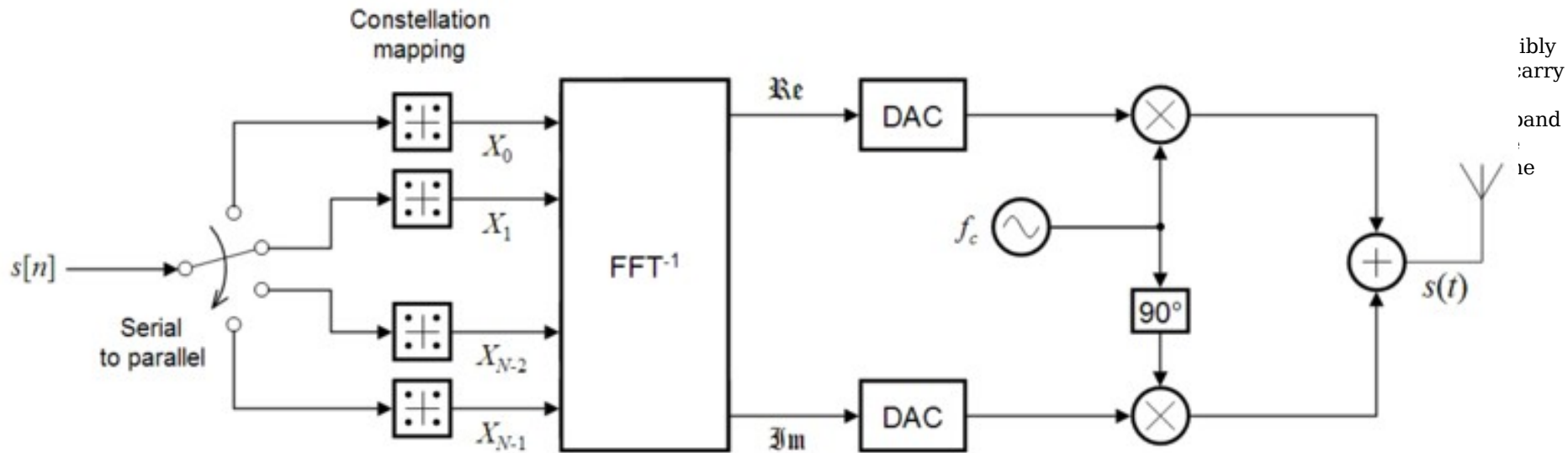

Fig. 1: Generation of the DAB Signal

Transmitter

An OFDM carrier signal is the sum of a number of orthogonal sub-carriers, with **baseband** data on each sub-carrier being independently modulated commonly using some type of **quadrature** amplitude modulation (QAM) or **phase-shift keying** (PSK). This composite baseband signal is typically used to modulate a main **RF** carrier.



ibly
arry
and
ie

Figure 2 demonstrates a conceptual DAB receiver. The DAB ensemble is selected in the analogue tuner., the digitised output of which is fed to the OFDM demodulator and channel decoder to eliminate transmission errors. The information contained in the FIC is passed to the user interface for service selection and is used to set p the receiver appropriately. The MSC data is further processed in an audio decoder to produce the left and right audio signals or in a data decoder (Packet Demux) as appropriate.

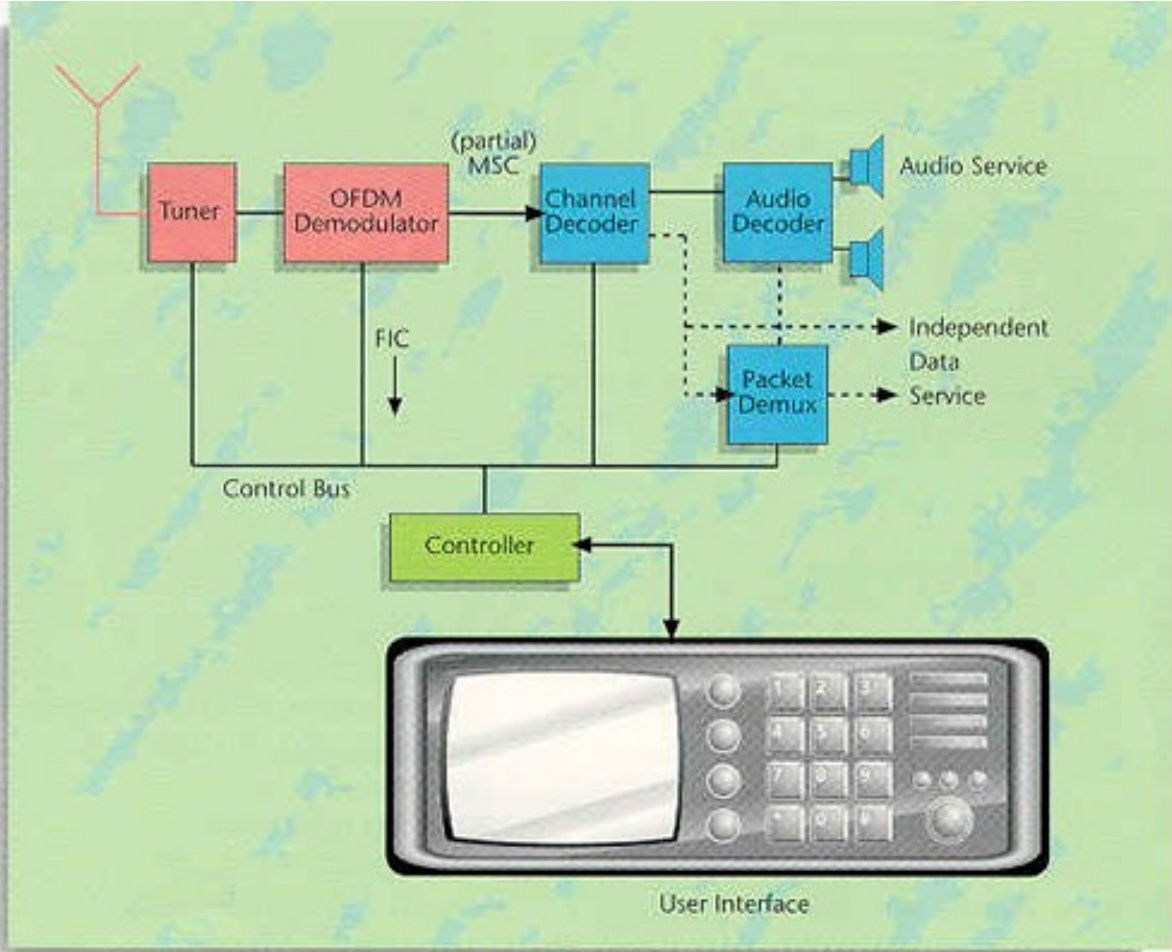
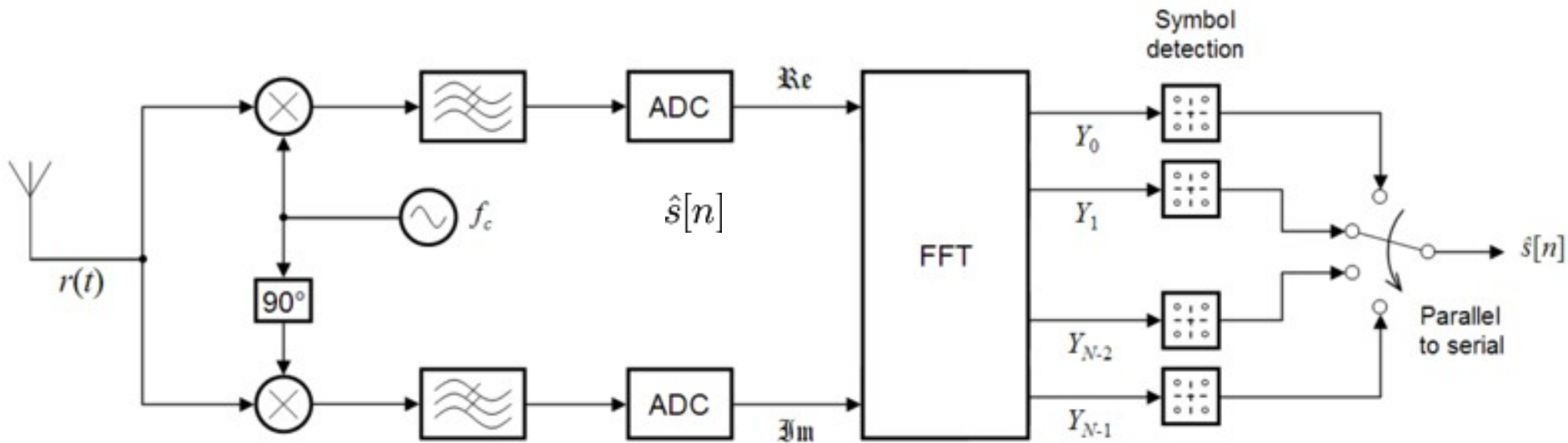

Fig. 2 : Conceptual DAB Receiver

Receiver

The receiver picks up the signal $r(t)$, which is then quadrature-mixed down to baseband using cosine and sine waves at the carrier frequency. This also creates signals centered on $2f_c$, so low-pass filters are used to reject these. The baseband signals are then sampled and digitised using [analogue-to-digital converters](#) (ADCs), and a forward FFT is used to convert back to the frequency domain.

This returns N parallel streams, each of which is converted to a binary stream using an appropriate [symbol detector](#). These streams are then re-



Mathematical description

If N sub-carriers are used, and each sub-carrier is modulated using M alternative symbols, the OFDM symbol alphabet consists of M^N combined symbols.

The **low-pass equivalent** OFDM signal is expressed as:

$$\nu(t) = \sum_{k=0}^{N-1} X_k e^{i2\pi kt/T}, \quad 0 \leq t < T,$$

where $\{X_k\}$ are the data symbols, N is the number of sub-carriers, and T is the OFDM symbol time. The sub-carrier spacing of $1/T$ makes them orthogonal over each symbol period; this property is

$$\begin{aligned} \text{ex } & \frac{1}{T} \int_0^T (e^{i2\pi k_1 t/T})^* (e^{i2\pi k_2 t/T}) dt \\ & = \frac{1}{T} \int_0^T e^{i2\pi(k_2 - k_1)t/T} dt = \begin{cases} 1, & k_1 = k_2 \\ 0, & k_1 \neq k_2 \end{cases} \end{aligned}$$

$(\cdot)^*$

where $(\cdot)^*$ denotes the **complex conjugate** operator.

To avoid intersymbol interference in multipath fading channels, a guard interval $-T_g \leq t < 0$ is inserted prior to the OFDM interval $0 \leq t < T$, a *cyclic prefix* is transmitted such that the signal in the interval $-T_g \leq t < 0$ equals the signal in the interval $0 \leq t < T_g$.

The signal with cyclic prefix is thus:

$$\nu(t) = \sum_{k=0}^{N-1} X_k e^{i2\pi kt/T}, \quad -T_g \leq t < T$$

The low-pass signal above can be either real or complex-valued. Real-valued low-pass equivalent signals are typically transmitted at baseband—wireline applications such as DSL use this approach. For wireless applications, the low-pass signal is typically complex-valued; in which case, the transmitted signal is up-converted to a carrier frequency f_c . In general, the transmitted signal can be represented as:

$$\begin{aligned} s(t) &= \frac{1}{2} \Re \{ \nu(t) e^{i2\pi f_c t} \} \\ &= \sum_{k=0}^{N-1} |X_k| \cos(2\pi [f_c + k/T]t + \arg[X_k]) \end{aligned}$$

DAB standard: 170 MHz ... 230 MHz

L-band.

200MHz BAND. Mode I:

- symbols of 1ms useful duration with a guard interval of 0.246 ms.

- 1536 sub-carriers transmitted simultaneously per symbol

- a QPSK code for each sub-carrier

- symbols are organised into frames of 77 symbols.

- the first symbol is a null one (with no-frequency transmitted or only the centre frequency)

- the second symbol is the reference one where all the sub-carriers are transmitted with reference code elements.

This symbol is used for the propagation channel estimation.

-

- A “typical” radiated power for DAB transmitters 1 kW.

1.5MHz bandwidth (1536 orthogonal sub-carriers of 1kHz bandwidth each).

White spectrum !

DAB signal structure

