

Ordered weighted enhancement of preference modeling in the reference point method for multiple criteria optimization

Włodzimierz Ogryczak

Received: date / Accepted: date

Abstract The Reference Point Method (RPM) is an interactive technique for multiple criteria optimization problems. It is based on optimization of the scalarizing achievement function built as the augmented max-min aggregation of individual outcomes with respect to the given reference levels. Actually, the worst individual achievement is optimized, but regularized with the term representing the average achievement. In order to avoid inconsistencies caused by the regularization, we apply the Ordered Weighted Averages (OWA) with monotonic weights to combine all the individual achievements. Further, following the concept of the Weighted OWA (WOWA), we incorporate the importance weighting of several achievements into the RPM. We show that the resulting WOWA RPM can be quite effectively implemented as an extension of the original constraints and criteria with simple linear inequalities.

Keywords Multicriteria Decision Making · Aggregation Methods · Reference Point Method · OWA · WOWA

1 Introduction

Consider a decision problem defined as an optimization problem with m criteria (objective functions). In this paper, without loss of generality, it is assumed that all the criteria are maximized (that is, for each outcome

‘more is better’). Hence, we consider the following Multiple Criteria Optimization (MCO) problem:

$$\max \{ (f_1(\mathbf{x}), \dots, f_m(\mathbf{x})) : \mathbf{x} \in Q \} \quad (1)$$

where \mathbf{x} denotes a vector of decision variables to be selected from the feasible set $Q \subset R^n$, and $\mathbf{f}(x) = (f_1(\mathbf{x}), f_2(\mathbf{x}), \dots, f_m(\mathbf{x}))$ is a vector function that maps the feasible set Q into the criterion space R^m . Note that neither any specific form of the feasible set Q is assumed nor any special form of criteria $f_i(\mathbf{x})$ is required. We refer to the elements of the criterion space as outcome vectors. An outcome vector \mathbf{y} is attainable if it expresses outcomes of a feasible solution, i.e., $\mathbf{y} = \mathbf{f}(\mathbf{x})$ for some $\mathbf{x} \in Q$. The set of all attainable outcome vectors will be denoted by Y .

The model (1) only specifies that we are interested in maximization of all objective functions f_i for $i \in I = \{1, 2, \dots, m\}$. Thus, it allows only to identify (to eliminate) obviously inefficient solutions leading to dominated outcome vectors, while still leaving the entire efficient set to look for a satisfactory compromise solution. In order to make the multiple criteria model operational for the decision support process, one needs assume some solution concept well adjusted to the DM preferences. This can be achieved with the so-called quasi-satisficing approach to multiple criteria decision problems. The best formalization of the quasi-satisficing approach to multiple criteria optimization was proposed and developed mainly by Wierzbicki [25] as the Reference Point Method (RPM). The reference point method was later extended to permit additional information from the DM and, eventually, led to efficient implementations of the so-called Aspiration/Reservation Based Decision Support (ARBDS) approach with many successful applications [1, 4, 14, 27].

W. Ogryczak

Warsaw University of Technology, Institute of Control and Computation Engineering, 00-665 Warsaw, Poland

Tel.: +48-22-2347750

Fax: +48-22-8253719

E-mail: W.Ogryczak@ia.pw.edu.pl

The RPM is an interactive technique. The basic concept of the interactive scheme is as follows. The DM specifies requirements in terms of reference levels, i.e., by introducing reference (target) values for several individual outcomes. Depending on the specified reference levels, a special scalarizing achievement function is built, which may be directly interpreted as expressing utility to be maximized. Maximization of the scalarizing achievement function generates an efficient solution to the multiple criteria problem. The computed efficient solution is presented to the DM as the current solution in a form that allows comparison with the previous solutions, and modification of the reference levels if necessary.

The scalarizing achievement function can be viewed as two-stage transformation of the original outcomes. First, the strictly monotonic component achievement functions are built to measure individual performance with respect to given reference levels. Having all the outcomes transformed into a uniform scale of individual achievements, they are aggregated at the second stage to form a unique scalarization. The RPM is based on the so-called augmented (or regularized) max-min aggregation. Thus, the worst individual achievement is essentially maximized, but the optimization process is additionally regularized with the term representing the average achievement. The max-min aggregation guarantees fair treatment of all individual achievements by implementing an approximation to the Rawlsian principle of justice.

The max-min aggregation is crucial for allowing the RPM to generate all efficient solutions even for non-convex (and particularly discrete) problems. On the other hand, the regularization is necessary to guarantee that only efficient solutions are generated. The regularization by the average achievement is easily implementable, but it may disturb the basic max-min model. Actually, the only consequent regularization of the max-min aggregation is the lex-min order or, more practical, the OWA aggregation with monotonic weights. The latter combines all the component achievements allocating the largest weight to the worst achievement, the second largest weight to the second worst achievement, the third largest weight to the third worst achievement, and so on. The recent progress in optimization methods for ordered averages [17] allows one to implement the OWA RPM quite effectively. Further, following the concept of Weighted OWA [23,24], the importance weighting of several achievements may be incorporated into the RPM. Such a WOWA enhancement of the RPM uses importance weights to affect achievement importance by rescaling accordingly its measure within the distribution of achievements rather

than straightforward rescaling of achievement values [22]. The paper analyzes both the theoretical and implementation issues of the WOWA enhanced RPM.

The paper is organized as follows. In the next section the scalarizing achievement functions are discussed and related to the fuzzy multicriteria optimization. In Section 3 there is introduced and analyzed the OWA refinement of the RPM. The OWA RPM model is further extended in Section 4 to accommodate the importance weights following the WOWA methodology. Linear Programming computational model for the WOWA RPM method is introduced. In Section 5 an illustrative example is discussed.

2 RPM and Fuzzy Targets

In the RPM method, depending on the specified reference levels, a special scalarizing achievement function is built which, when optimized, generates an efficient solution to the problem. While building the scalarizing achievement function, some basic properties of the preference model are assumed. First of all, the following property is required:

P1: The preference model corresponding to the scalarizing achievement function optimization is consistent with the Pareto order and therefore each solution generated by the scalarizing function optimization is an efficient solution of the original MCO problem.

To meet this requirement the preference model corresponding to the scalarizing achievement function optimization is strictly monotonic in the sense that an increase of any outcome y_i leads to a preferred solution. Actually, the function must be strictly increasing with respect to each individual outcome.

Second, the scalarizing achievement function optimization must enforce reaching the reference levels prior to further improving of criteria. Hence, the following property is required:

P2: The preference model corresponding to the scalarizing achievement function optimization guarantees that a solution with all individual outcomes satisfying the corresponding reference levels is preferred to any solution with at least one individual outcome worse than its reference level.

Thus, similar to the goal programming approaches, the reference levels are treated as targets, but following the quasi-satisficing approach, they are interpreted consistently with basic concepts of efficiency in the sense that the optimization is continued even when the target point has been reached already [27].

The generic scalarizing achievement function takes the following form [25]:

$$S(\mathbf{a}) = \min_{1 \leq i \leq m} \{a_i\} + \frac{\varepsilon}{m} \sum_{i=1}^m a_i \quad (2)$$

where ε is an arbitrary small positive number and $a_i = s_i(f_i(\mathbf{x}))$ for $i = 1, 2, \dots, m$ are the component achievements measuring actual performances of the individual outcomes with component achievement functions $s_i: R \rightarrow R$ for $i = 1, 2, \dots, m$ defined with respect to the corresponding reference levels. Let a_i denote the component achievement for the i th outcome ($a_i = s_i(y_i) = s_i(f_i(\mathbf{x}))$), and let $\mathbf{a} = (a_1, a_2, \dots, a_m) = \mathbf{s}(\mathbf{y})$ represent the entire achievement vector. During the interactive analysis, the scalarizing achievement function is maximized in order to generate an efficient solution as a current solution, i.e.

$$\max_{\mathbf{x} \in Q} S(\mathbf{s}(\mathbf{f}(\mathbf{x}))) = \max_{\mathbf{a} \in A} S(\mathbf{a}) \quad (3)$$

where

$$A = \{\mathbf{a} = \mathbf{s}(\mathbf{y}) : \mathbf{y} \in Y\} = \{\mathbf{a} = \mathbf{s}(\mathbf{f}(\mathbf{x})) : \mathbf{x} \in Q\}. \quad (4)$$

Note that we will use simplified notation of optimization over the achievement set A although still assuming that according to (4) the optimal solution $\bar{\mathbf{a}}$ is generated by an optimal decision vector $\bar{\mathbf{x}}$ such that $\bar{\mathbf{a}} = \mathbf{s}(\mathbf{f}(\bar{\mathbf{x}}))$.

The scalarizing achievement function (2) is essentially defined by the worst component achievement but additionally regularized with the sum of all component achievements. The regularization term is introduced in order to guarantee the efficiency of the optimal solution in the case when the maximization of the main term (the worst component achievement) results in a non-unique optimal solution. Due to combining two terms with arbitrary small parameter ε , formula (2) is easily implementable and it provides a direct interpretation of the scalarizing achievement function as expressing utility. When accepting the loss of a direct utility interpretation, one may consider a limiting case with $\varepsilon \rightarrow 0_+$, which results in lexicographic order applied to two separate terms of function (2). That means, the regularization can be implemented with the second level lexicographic optimization [14]. Therefore, RPM may be also considered as the following lexicographic problem ([12] and references therein):

$$\text{lex max}_{\mathbf{a} \in A} \left(\min_{1 \leq i \leq m} a_i, \sum_{i=1}^m a_i \right) \quad (5)$$

Various functions s_i provide a wide modeling environment for measuring component achievements [26, 27, 9, 11]. The basic RPM model is based on the single vector of the reference levels, the aspiration vector \mathbf{r}^a . For the sake of computational simplicity, the piecewise

linear functions s_i are usually employed. In the simplest models, they take a form of two segment piecewise linear functions:

$$s_i(y_i) = \begin{cases} \lambda_i^+(y_i - r_i^a), & \text{for } y_i \geq r_i^a \\ \lambda_i^-(y_i - r_i^a), & \text{for } y_i < r_i^a \end{cases} \quad (6)$$

where $\lambda_i^+ > \lambda_i^-$ are positive scaling factors corresponding to underachievements and overachievements, respectively, for the i th outcome. It is usually assumed that λ_i^+ is much larger than λ_i^- . Figure 1 depicts how differentiated scaling affects the isoline contours of the scalarizing achievement function.

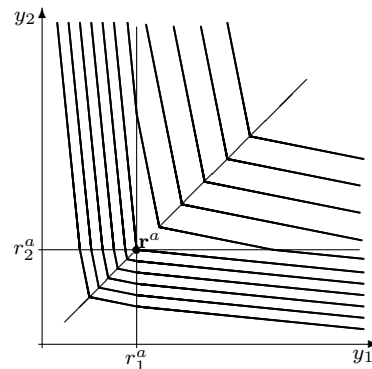

Fig. 1 Isoline contours for the scalarizing achievement function (2) with component achievements (6)

Real-life applications of the RPM methodology usually deal with more complex component achievement functions defined with more than one reference point [27] which enriches the preference models and simplifies the interactive analysis. In particular, the models taking advantages of two reference vectors: vector of aspiration levels \mathbf{r}^a and vector of reservation levels \mathbf{r}^r [4] are used, thus allowing the DM to specify requirements by introducing acceptable and required values for several outcomes. The component achievement function s_i can be interpreted then as a measure of the DM's satisfaction with the current outcome value of the i th criterion. It is a strictly increasing function of outcome y_i with value $a_i = 1$ if $y_i = r_i^a$, and $a_i = 0$ for $y_i = r_i^r$. Thus the component achievement functions map the outcomes values onto a normalized scale of the DM's satisfaction. Various functions can be built meeting those requirements. We use the piece-wise linear component achievement function introduced in an implementation of the ARBDS system for the multiple criteria transshipment problems with facility location [16]:

$$s_i(y_i) = \begin{cases} \gamma \frac{y_i - r_i^r}{r_i^a - r_i^r}, & y_i \leq r_i^r \\ \frac{y_i - r_i^r}{r_i^a - r_i^r}, & r_i^r < y_i < r_i^a \\ \alpha \frac{y_i - r_i^a}{r_i^a - r_i^r} + 1, & y_i \geq r_i^a \end{cases} \quad (7)$$

where α and γ are arbitrary parameters satisfying $0 < \alpha < 1 < \gamma$. The parameter α represents additional increase of the DM's satisfaction over level 1 when a criterion generates outcomes better than the corresponding aspiration level. On the other hand, the parameter $\gamma > 1$ represents dissatisfaction connected with outcomes worse than the reservation level (Fig. 2).

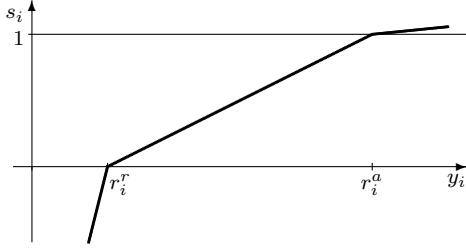

Fig. 2 Component achievement function (7)

The lexicographic RPM model (5) used with the component achievement function (7) guarantees that the crucial properties of the quasi-satisficing decision model are fulfilled. Indeed, the following theorem is valid [10].

Theorem 1 *The preference model corresponding to the lexicographic optimization (5) and (7) has the following properties:*

1. *It is strictly monotonic in the sense that an increase of any outcome y_i leads to a preferred solution;*
2. *It guarantees that for any given target value ϱ , the solution generating all component achievements equal to ϱ ($a_i = \varrho \forall i$) is preferred to any solution generating at least one component achievement worse than ϱ .*

Note that following the property 1, every solution optimal to the lexicographic optimization (5) with (7) is an efficient solution to the MCO problem (the property **P1**). Further, following the property 2, the solution reaching all the reservation levels is preferred to any solution failing achievement of at least one reservation level ($\varrho = 0$) as well as the solution reaching all the aspiration levels is preferred to any solution failing achievement of at least one aspiration level ($\varrho = 1$). Thus, the property **P2** is satisfied in terms of the ARBDS methodology. Note that this property is only approximated in the case of the analytic scalarizing achievement function (2) since the regularization term may disturb those preferences.

For outcomes between the reservation and the aspiration levels, the component achievement function s_i

can be interpreted as a membership function μ_i for a fuzzy target.

$$\mu_i(y_i) = \begin{cases} 0, & y_i \leq r_i^r \\ \frac{y_i - r_i^r}{r_i^a - r_i^r}, & r_i^r < y_i < r_i^a \\ 1, & y_i \geq r_i^a \end{cases} \quad (8)$$

However, such a membership function remains constant with value 1 for all outcomes greater than the corresponding aspiration level, and with value 0 for all outcomes below the reservation level (Fig. 3). Hence, the fuzzy membership function is neither strictly monotonic nor concave thus not representing typical utility for a maximized outcome. The component achievement function (7) can be viewed as an extension of the fuzzy membership function to a strictly monotonic and concave utility. One may also notice that the aggregation scheme used to build the scalarizing achievement function (2) from the component functions may also be interpreted as some fuzzy aggregation operator [27]. In other words, maximization of the scalarizing achievement function (2) is consistent with the fuzzy methodology in the case of not attainable aspiration levels and satisfiable all reservation levels while modeling a reasonable utility for any values of aspiration and reservation levels.

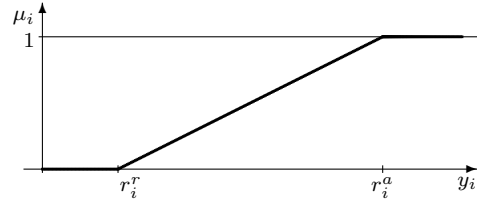

Fig. 3 Fuzzy membership function (8)

Theorem 2 *If outcome vector $\bar{\mathbf{y}} \in Y$ generates an optimal solution of the lexicographic RPM problem (5) with the piecewise linear component achievement functions (7), then $\bar{\mathbf{y}}$ is an optimal solution of the corresponding fuzzy targets intersection optimization problem*

$$\max_{\mathbf{y} \in Y} \left[\min_{1 \leq i \leq m} \mu_i(y_i) \right] \quad (9)$$

Proof Let $\bar{\mathbf{a}} = \mathbf{s}(\bar{\mathbf{y}})$, with s_i defined according to (7), be an optimal solution of the lexicographic RPM problem (5). Suppose that $\bar{\mathbf{y}}$ is not optimal to problem (9). This means $\min_{1 \leq i \leq m} \mu_i(\bar{y}_i) = \mu_{i_0}(\bar{y}_{i_0}) = \bar{\varrho} < 1$ and there exists $\tilde{\mathbf{y}} \in Y$ such that $\mu_i(\tilde{y}_i) \geq \tilde{\varrho} > \bar{\varrho}$ for all $i \in I$. Note that $\bar{\varrho} < 1$ and $\tilde{\varrho} > 0$. Hence, $s_i(\tilde{y}_i) \geq \mu_i(\tilde{y}_i)$ for all $i \in I$ and $\mu_{i_0}(\bar{y}_{i_0}) \geq s_{i_0}(\bar{y}_{i_0})$. Thus, $s_i(\tilde{y}_i) \geq \tilde{\varrho} > \bar{\varrho} \geq s_{i_0}(\bar{y}_{i_0}) \geq \min_{1 \leq i \leq m} s_i(\bar{y}_i)$, which contradicts optimality of $\bar{\mathbf{y}}$ with respect to the

maxmin optimization $\max_{\mathbf{y} \in Y} [\min_{1 \leq i \leq m} s_i(y_i)]$ and also to the lexicographic RPM problem (5).

Under the assumption that the parameters α and γ satisfy inequalities $0 < \alpha < 1 < \gamma$, the component achievement function (7) is strictly increasing and concave. Hence, it can be expressed in the form:

$$s_i(y_i) = \min \left\{ \gamma \frac{y_i - r_i^r}{r_i^a - r_i^r}, \frac{y_i - r_i^r}{r_i^a - r_i^r}, \alpha \frac{y_i - r_i^a}{r_i^a - r_i^r} + 1 \right\}$$

which guarantees LP computability with respect to outcomes y_i . Finally, maximization of the entire scalarizing achievement function (5) can be implemented by the following auxiliary LP constraints:

$$\begin{aligned} \text{lex max } & (\underline{a}, \sum_{i=1}^m a_i) \\ \text{s.t. } & \underline{a} \leq a_i \quad \forall i \in I \\ & a_i \leq \gamma \frac{y_i - r_i^r}{r_i^a - r_i^r} \quad \forall i \in I \\ & a_i \leq \frac{y_i - r_i^r}{r_i^a - r_i^r} \quad \forall i \in I \\ & a_i \leq \alpha \frac{y_i - r_i^a}{r_i^a - r_i^r} + 1 \quad \forall i \in I \end{aligned}$$

where a_i for $i = 1, \dots, m$ and \underline{a} are unbounded variables introduced to represent values of several component achievement functions and their minimum, respectively.

On the other hand, the fuzzy model (9) requires the use of some binary variables. In the simplest form it can be formulated as follows

$$\begin{aligned} \text{max } & \underline{a} \\ \text{s.t. } & \underline{a} \leq a_i \quad \forall i \in I \\ & a_i \leq 1 - u_i \quad \forall i \in I \\ & a_i \leq \frac{y_i - r_i}{r_i - r_i} + M u_i \quad \forall i \in I \\ & u_i \leq \frac{r_i - y_i}{M(a_i - r_i)} + 1 \quad \forall i \in I \end{aligned}$$

where M is a large constant and u_i are binary variables satisfying $y_i > r_i \Rightarrow u_i = 0$, due to the last inequality. Hence, the lexicographic RPM problem (5) with the piecewise linear component achievement functions (7) allow us to select efficient solutions among various alternative optimal solutions of the corresponding fuzzy targets intersection optimization problem (9). Simultaneously, the corresponding RPM problem is much more simpler with respect to its computational complexity.

3 OWA Refinement of the RPM

The crucial properties of the RPM are related to the max-min aggregation of the component achievements.

The regularization is introduced in order to guarantee the aggregation monotonicity. Unfortunately, the distribution of achievements may make the max-min criterion partially passive when one specific achievement is relatively very small for all the solutions. Maximization of the worst achievement may then leave all other achievements unoptimized. The selection is then made according to linear aggregation of the regularization term instead of the max-min aggregation, thus destroying the preference model of the RPM. This can be illustrated with an example of a simple discrete problem of 7 alternative feasible solutions to be selected according to 6 criteria. Table 1 presents six component achievements for all the solutions, where the component achievements have been defined according to the aspiration/reservation model (7) thus allocating 1 to outcomes reaching the corresponding aspiration level. All the solutions are efficient. Solution S1 to S5 reach aspiration levels (achievement values 1.0) for four of the first five criteria while failing to reach one of them and the aspiration level for the sixth criterion as well (achievement values 0.1). Solution S6 is close to the aspiration levels (achievement values 0.8) for the first five criteria while failing to reach the aspiration level for the sixth criterion (achievement values 0.1). All the solutions generate the same worst achievement value 0.1 and the final selection of the RPM depends on the total achievement (regularization term). Actually, one of solutions S1 to S5 will be selected as better than S6.

Table 1 Sample achievements with passive max-min criterion

Sol.	a_1	a_2	a_3	a_4	a_5	a_6	min	Σ
S1	0.1	1.0	1.0	1.0	1.0	0.1	0.1	4.2
S2	1.0	0.1	1.0	1.0	1.0	0.1	0.1	4.2
S3	1.0	1.0	0.1	1.0	1.0	0.1	0.1	4.2
S4	1.0	1.0	1.0	0.1	1.0	0.1	0.1	4.2
S5	1.0	1.0	1.0	1.0	0.1	0.1	0.1	4.2
S6	0.8	0.8	0.8	0.8	0.8	0.1	0.1	4.1
S7	0.1	0.1	0.1	0.8	0.4	0.8	0.1	2.3

One may easily notice that eliminating from the consideration alternative S7 we get the sixth component achievement (and the corresponding criterion) constant for the six alternatives under consideration. Hence, one may expect the same solution selected while taking into account this criterion or not. If focusing on five first criteria, then the RPM (either lexicographic (5) or analytic (2)) obviously selects solution S6 as reaching the worst achievement value 0.8.

In order to avoid inconsistencies caused by the regularization, the max-min solution may be regularized according to the ordered averaging rules [28]. This is mathematically formalized as follows. Within

the space of achievement vectors, we introduce map $\Theta = (\theta_1, \theta_2, \dots, \theta_m)$, which orders the coordinates of achievements vectors in a nonincreasing order, i.e., $\Theta(a_1, a_2, \dots, a_m) = (\theta_1(\mathbf{a}), \theta_2(\mathbf{a}), \dots, \theta_m(\mathbf{a}))$ iff there exists a permutation τ such that $\theta_i(\mathbf{a}) = a_{\tau(i)}$ for all i and $\theta_1(\mathbf{a}) \geq \theta_2(\mathbf{a}) \geq \dots \geq \theta_m(\mathbf{a})$. The standard max-min aggregation depends on maximization of $\theta_m(\mathbf{a})$ and it ignores values of $\theta_i(\mathbf{a})$ for $i \leq m - 1$. In order to take into account all the achievement values, one needs to maximize the weighted combination of the ordered achievements thus representing the so-called Ordered Weighted Averaging (OWA) aggregation [28]. Note that the weights are then assigned to the specific positions within the ordered achievements rather than to the component achievements themselves. With the OWA aggregation one gets the following RPM model:

$$\max_{\mathbf{a} \in A} \sum_{i=1}^m w_i \theta_i(\mathbf{a}) \quad (10)$$

where $w_1 < w_2 < \dots < w_m$ are positive and strictly increasing weights. Actually, they should be significantly increasing to represent regularization of the max-min order. When differences among weights tend to infinity, the OWA aggregation approximates the leximin ranking of the ordered outcome vectors [29]. Note that the standard RPM model with the scalarizing achievement function (2) can be expressed as the following OWA model:

$$\max_{\mathbf{a} \in A} \left(\left(1 + \frac{\varepsilon}{m}\right) \theta_m(\mathbf{a}) + \frac{\varepsilon}{m} \sum_{i=1}^{m-1} \theta_i(\mathbf{a}) \right)$$

Hence, the standard RPM model exactly represents the OWA aggregation (10) with strictly increasing weights in the case of $m = 2$ ($w_1 = \varepsilon/2 < w_2 = 1 + \varepsilon/2$). For $m > 2$ it abandons the differences in weighting of the largest achievement, the second largest one, etc ($w_1 = \dots = w_{m-1} = \varepsilon/m$). The OWA RPM model (10) allows one to distinguish all the weights by introducing increasing series (e.g. geometric ones). One may notice in Table 2 that application of increasing weights $\mathbf{w} = (0.02, 0.03, 0.05, 0.15, 0.25, 0.5)$ within the OWA RPM enables the selection of solution S6 from Table 1. On the other hand, the OWA RPM model (10) similar to that of (2) does not fulfill completely the preference model of the reference vectors (property **P2**).

When accepting the loss of a direct utility interpretation, one may consider more powerful lexicographic preference modeling [11, 12] based on the linear component achievement function

$$a_i = s_i(f_i(\mathbf{x})) = (f_i(\mathbf{x}) - r_i^r) / (r_i^a - r_i^r) \quad \forall i \in I \quad (11)$$

Table 2 Ordered achievements values

Sol.	θ_1	θ_2	θ_3	θ_4	θ_5	θ_6	$A_{\mathbf{w}}$
S1	1.0	1.0	1.0	1.0	0.1	0.1	0.505
S2	1.0	1.0	1.0	1.0	0.1	0.1	0.505
S3	1.0	1.0	1.0	1.0	0.1	0.1	0.505
S4	1.0	1.0	1.0	1.0	0.1	0.1	0.505
S5	1.0	1.0	1.0	1.0	0.1	0.1	0.505
S6	0.8	0.8	0.8	0.8	0.8	0.1	0.630
S7	0.8	0.8	0.4	0.1	0.1	0.1	0.285
\mathbf{w}	0.02	0.03	0.05	0.15	0.25	0.5	

Table 3 Sample aspiration underachievements

Sol.	a_1^a	a_2^a	a_3^a	a_4^a	a_5^a	a_6^a
S1	0.9	0.0	0.0	0.0	0.0	0.9
S2	0.0	0.9	0.0	0.0	0.0	0.9
S3	0.0	0.0	0.9	0.0	0.0	0.9
S4	0.0	0.0	0.0	0.9	0.0	0.9
S5	0.0	0.0	0.0	0.0	0.9	0.9
S6	0.2	0.2	0.2	0.2	0.2	0.9
S7	0.9	0.9	0.9	0.2	0.6	0.2

but splitted into separate preemptive multilevel interval achievement measures: the reservation level underachievement

$$a_i^r = s_i^r(f_i(\mathbf{x})) = \frac{(r_i^r - f_i(\mathbf{x}))_+}{r_i^a - r_i^r} \quad \forall i \in I,$$

the aspiration level underachievement

$$a_i^a = s_i^a(f_i(\mathbf{x})) = \min\left\{\frac{(r_i^a - f_i(\mathbf{x}))_+}{r_i^a - r_i^r}, 1\right\} \quad \forall i \in I$$

and the aspiration level overachievement

$$a_i^o = s_i^o(f_i(\mathbf{x})) = \frac{(f_i(\mathbf{x}) - r_i^a)_+}{r_i^a - r_i^r} \quad \forall i \in I.$$

Taking into account (11), they can be rewritten as

$$\begin{aligned} a_i^r &= (-a_i)_+ & \forall i \in I \\ a_i^a &= \min\{(1 - a_i)_+, 1\} & \forall i \in I \\ a_i^o &= (a_i - 1)_+ & \forall i \in I \end{aligned} \quad (12)$$

For instance, sample achievements from Table 1 represent all the results between the reservation and aspiration levels. Hence, the corresponding reservation underachievements are equal zero ($\mathbf{a}^r = 0$) and similarly all the aspiration overachievements ($\mathbf{a}^o = 0$) while the aspiration underachievement are given in Table 3.

Maximization of the scalarizing achievement function (10) is replaced with the lexicographic minimization of the multilevel aggregations:

$$\text{lex min}_{\mathbf{a} \in A} \{ (A_{\mathbf{w}}(\mathbf{a}^r), A_{\mathbf{w}}(\mathbf{a}^a), A_{\mathbf{w}}(-\mathbf{a}^o)) : \text{Eq. (11)-(12)} \} \quad (13)$$

with positive and strictly decreasing weights $w_1 > w_2 > \dots > w_m > 0$. One may notice in Table 4 that application of decreasing weights $\mathbf{w} =$

Table 4 Ordered aspiration underachievements with passive min-max criterion

Sol.	θ_1	θ_2	θ_3	θ_4	θ_5	θ_6	$A_{\mathbf{w}}(\mathbf{a}^a)$
S1	0.9	0.9	0.0	0.0	0.0	0.0	0.675
S2	0.9	0.9	0.0	0.0	0.0	0.0	0.675
S3	0.9	0.9	0.0	0.0	0.0	0.0	0.675
S4	0.9	0.9	0.0	0.0	0.0	0.0	0.675
S5	0.9	0.9	0.0	0.0	0.0	0.0	0.675
S6	0.9	0.2	0.2	0.2	0.2	0.2	0.550
S7	0.9	0.9	0.9	0.6	0.2	0.2	0.895
\mathbf{w}	0.5	0.25	0.15	0.05	0.03	0.02	

(0.5, 0.25, 0.15, 0.05, 0.03, 0.02) within the OWA RPM (13) enables the selection of solution S6 from Table 3.

Problem (13) always generates an efficient solution to the original MCO problem complying simultaneously with the ARBDS preference model assumptions.

Theorem 3 For any reference levels $r_i^a > r_i^r$, any positive weights \mathbf{w} , if $(\bar{\mathbf{a}}^r, \bar{\mathbf{a}}^a, \bar{\mathbf{a}}^o)$ is an optimal solution of the problem (13), then any decision vector $\bar{\mathbf{x}} \in Q$ generating this solution is an efficient solution of the corresponding MCO problem (1).

Proof Let $\bar{\mathbf{x}}$ be a feasible vector generating $(\bar{\mathbf{a}}^r, \bar{\mathbf{a}}^a, \bar{\mathbf{a}}^o)$ optimal to the problem (13) with some positive weight vector \mathbf{w} . Suppose that $\bar{\mathbf{x}}$ is not efficient to the MCO problem (1). This means, there exists a decision vector $\mathbf{x} \in Q$ such that $f_i(\mathbf{x}) \geq f_i(\bar{\mathbf{x}})$ for all $i \in I$ and $f_{i_o}(\mathbf{x}) > f_{i_o}(\bar{\mathbf{x}})$ for some outcome index $i_o \in I$. Let us define a_i^r , a_i^a and a_i^o according to formula (12). The triple $(\mathbf{a}^r, \mathbf{a}^a, \mathbf{a}^o)$ is then a feasible solution of the problem (13). Moreover, $a_i^r \leq \bar{a}_i^r$, $a_i^a \leq \bar{a}_i^a$ and $a_i^o \geq \bar{a}_i^o$ for all $i \in I$, where at least one of strict inequalities $a_{i_o}^r < \bar{a}_{i_o}^r$ or $a_{i_o}^a < \bar{a}_{i_o}^a$ or $a_{i_o}^o > \bar{a}_{i_o}^o$ holds. Hence, due to strict monotonicity of the OWA aggregation with positive weighting vectors, one gets $A_{\mathbf{w}}(\mathbf{a}^r) \leq A_{\mathbf{w}}(\bar{\mathbf{a}}^r)$, $A_{\mathbf{w}}(\mathbf{a}^a) \leq A_{\mathbf{w}}(\bar{\mathbf{a}}^a)$ and $A_{\mathbf{w}}(-\mathbf{a}^o) \leq A_{\mathbf{w}}(-\bar{\mathbf{a}}^o)$ with at least one inequality strict. The latest assertion contradicts the lexicographic optimality of $(\bar{\mathbf{a}}^r, \bar{\mathbf{a}}^a, \bar{\mathbf{a}}^o)$ for problem (13), which completes the proof.

Theorem 4 For any reference levels $r_i^a > r_i^r$, any positive weights \mathbf{w} , if $(\bar{\mathbf{a}}^r, \bar{\mathbf{a}}^a, \bar{\mathbf{a}}^o)$ is an optimal solution of the problem (13), then all the reservation level underachievements \bar{a}_i^r are equal 0 whenever there exists a feasible solution $\mathbf{x} \in Q$ such that $f_i(\mathbf{x}) \geq r_i^r$ for all $i \in I$.

Proof Let $(\bar{\mathbf{a}}^r, \bar{\mathbf{a}}^a, \bar{\mathbf{a}}^o)$ be an optimal solution of the problem (13) with some positive weight vector \mathbf{w} . Suppose that $\bar{a}_{i_o}^r < 0$ for some $i_o \in I$ and there exists a feasible solution $\mathbf{x} \in Q$ such that $f_i(\mathbf{x}) \geq r_i^r$ for all $i \in I$. Let us define a_i^r , a_i^a and a_i^o according to formula (12) and note that $a_i^r = 0$ for all $i \in I$. The triple $(\mathbf{a}^r, \mathbf{a}^a, \mathbf{a}^o)$

is then a feasible solution of problem (26) and, due to positive weights, $A_{\mathbf{w}}(\mathbf{a}^r) = 0 < A_{\mathbf{w}}(\bar{\mathbf{a}}^r)$ thus contradicting the lexicographic optimality of $(\bar{\mathbf{a}}^r, \bar{\mathbf{a}}^a, \bar{\mathbf{a}}^o)$.

Theorem 5 For any reference levels $r_i^a > r_i^r$, any positive weights \mathbf{w} , if $(\bar{\mathbf{a}}^r, \bar{\mathbf{a}}^a, \bar{\mathbf{a}}^o)$ is an optimal solution of the problem (13), then all the aspiration level underachievements \bar{a}_i^a are equal 0 whenever there exists a feasible solution $\mathbf{x} \in Q$ such that $f_i(\mathbf{x}) \geq r_i^a$ for all $i \in I$.

Proof Let $(\bar{\mathbf{a}}^r, \bar{\mathbf{a}}^a, \bar{\mathbf{a}}^o)$ be an optimal solution of the problem (13) with some positive weight vector \mathbf{w} . Suppose that $\bar{a}_{i_o}^a < 0$ for some $i_o \in I$ and there exists a feasible solution $\mathbf{x} \in Q$ such that $f_i(\mathbf{x}) \geq r_i^a$ for all $i \in I$. Let us define a_i^r , a_i^a and a_i^o according to formula (12) and note that $a_i^a = a_i^r = 0$ for all $i \in I$. The triple $(\mathbf{a}^r, \mathbf{a}^a, \mathbf{a}^o)$ is then a feasible solution of problem (26) and, due to positive weights, $A_{\mathbf{w}}(\mathbf{a}^a) = 0 < A_{\mathbf{w}}(\bar{\mathbf{a}}^a)$ thus contradicting the lexicographic optimality of $(\bar{\mathbf{a}}^r, \bar{\mathbf{a}}^a, \bar{\mathbf{a}}^o)$.

Note that following Theorem 3, every solution optimal to the OWA RPM problem (13) is an efficient solution to the MCO problem (property **P1**). Further, following Theorem 4, a solution reaching all the reservation levels is preferred to any solution failing achievement of at least one reservation level. Similarly, according to Theorem 5, a solution reaching all the aspiration levels is preferred to any solution failing achievement of at least one aspiration level. Thus, the property **P2** is satisfied in terms of the ARBDS methodology. The following theorem shows that for each efficient solution $\bar{\mathbf{x}}$ there exist aspiration and reservation vectors such that $\bar{\mathbf{x}}$ with the corresponding values of the multilevel achievements is an optimal solution of the problem (13) thus justifying the complete controllability of the interactive process by the aspiration levels.

Theorem 6 If $\bar{\mathbf{x}}$ is an efficient solution of the MCO problem (1), then there exist aspirations levels r_i^a such that the corresponding triple $(\bar{\mathbf{a}}^r, \bar{\mathbf{a}}^a, \bar{\mathbf{a}}^o)$ is an optimal solution of problem (13), for any reservation levels $r_i^r < r_i^a$ and any positive weight vector \mathbf{w} .

Proof Let us set the aspiration levels as $r_i^a = f_i(\bar{\mathbf{x}})$ for $i \in I$. For any reservation levels $r_i^r < r_i^a$, all the corresponding multilevel achievements defined according to the formula (12) take the zero values: $\bar{\mathbf{a}}^r = 0$, $\bar{\mathbf{a}}^a = 0$ and $\bar{\mathbf{a}}^o = 0$. Suppose that for some weights the triple $(0, 0, 0)$ is not an optimal solution of the corresponding problem (13). This means there exists a vector $\mathbf{x} \in Q$ such that $\mathbf{a}^r = 0$, $\mathbf{a}^a = 0$, $\mathbf{a}^o \geq 0$ and $A_{\mathbf{w}}(-\mathbf{a}^o) < A_{\mathbf{w}}(-\bar{\mathbf{a}}^o)$. Hence, $f_i(\mathbf{x}) \geq f_i(\bar{\mathbf{x}}) \forall i \in I$ and $f_{i_o}(\mathbf{x}) > f_{i_o}(\bar{\mathbf{x}})$ for some index $i_o \in I$. The latest

assertion contradicts the efficiency of $\bar{\mathbf{x}}$ to the MCO problem (1), which completes the proof.

Note that instead of (12), the interval achievements may be defined with the goal programming modeling techniques [14]:

$$\begin{aligned} a_i &= (f_i(\mathbf{x}) - r_i^r)/(r_i^a - r_i^r), & \forall i \in I \\ a_i - a_i^o + a_i^a + a_i^r &= 1, & \forall i \in I \\ a_i^o &\geq 0, \quad 0 \leq a_i^a \leq 1, \quad a_i^r \geq 0 & \forall i \in I \end{aligned} \quad (14)$$

Indeed, due to strict monotonicity of the OWA aggregation with positive weights [2,6], the following assertion may be applied to justify the OWA RPM model given as

$$\text{lex min}_{\mathbf{a} \in A} \{(A_{\mathbf{w}}(\mathbf{a}^r), A_{\mathbf{w}}(\mathbf{a}^a), A_{\mathbf{w}}(-\mathbf{a}^o)) : \text{Eq. (14)}\}. \quad (15)$$

Lemma 1 *For any strictly increasing scalarizing function g , if $(\bar{\mathbf{x}}, \bar{\mathbf{a}}^r, \bar{\mathbf{a}}^a, \bar{\mathbf{a}}^o)$ is an optimal solution of the problem*

$$\text{lex min}_{\mathbf{a} \in A} \{(g(\mathbf{a}^r), g(\mathbf{a}^a), g(-\mathbf{a}^o)) : \text{Eq. (14)}\}, \quad (16)$$

then it is an optimal solution of the problem

$$\text{lex min}_{\mathbf{a} \in A} \{(g(\mathbf{a}^r), g(\mathbf{a}^a), g(-\mathbf{a}^o)) : \text{Eq. (11)-(12)}\}. \quad (17)$$

Proof Let $(\bar{\mathbf{x}}, \bar{\mathbf{a}}^r, \bar{\mathbf{a}}^a, \bar{\mathbf{a}}^o)$ be an optimal solution of the problem (16). If \bar{a}_i^r , \bar{a}_i^a and \bar{a}_i^o fulfill the formula (12) for $\bar{\mathbf{x}}$, then the quadruple $(\bar{\mathbf{x}}, \bar{\mathbf{a}}^r, \bar{\mathbf{a}}^a, \bar{\mathbf{a}}^o)$ is an optimal solution of the corresponding problem (17). In order to prove that the formula (12) is satisfied, it is enough to show that $\bar{a}_i^o \bar{a}_i^a = 0$ and $(1 - \bar{a}_i^a) \bar{a}_i^r = 0$ for all $i \in I$ while obviously $\bar{a}_i^o \bar{a}_i^a \geq 0$ and $(1 - \bar{a}_i^a) \bar{a}_i^r \geq 0$ for all $i \in I$.

Suppose that $\bar{a}_{i_0}^o \bar{a}_{i_0}^a > 0$ for some index $i_0 \in I$. One may decrease then the values of both variables $\bar{a}_{i_0}^o$ and $\bar{a}_{i_0}^a$ by the same small positive number. This means, for sufficiently small positive number δ , the quadruple $(\bar{\mathbf{x}}, \bar{\mathbf{a}}^o - \delta \mathbf{e}_{i_0}, \bar{\mathbf{a}}^a - \delta \mathbf{e}_{i_0}, \bar{\mathbf{a}}^r)$, where \mathbf{e}_{i_0} denotes the unit vector corresponding to index i_0 , is feasible to problem (16). Due to the strictly increasing function g , one gets $(g(\bar{\mathbf{a}}^r), g(\bar{\mathbf{a}}^a - \delta \mathbf{e}_{i_0}), g(-\bar{\mathbf{a}}^o + \delta \mathbf{e}_{i_0})) <_{\text{lex}} (g(\bar{\mathbf{a}}^r), g(\bar{\mathbf{a}}^a), g(-\bar{\mathbf{a}}^o))$, which contradicts optimality of $(\bar{\mathbf{x}}, \bar{\mathbf{a}}^r, \bar{\mathbf{a}}^a, \bar{\mathbf{a}}^o)$ to the problem (16).

Further, suppose that $(1 - \bar{a}_{i_0}^a) \bar{a}_{i_0}^r > 0$ for some index $i_0 \in I$. One may decrease then the value of variable $\bar{a}_{i_0}^r$ and simultaneously increase $\bar{a}_{i_0}^a$ by the same small positive number. This means, for sufficiently small positive number δ , the quadruple $(\bar{\mathbf{x}}, \bar{\mathbf{a}}^r - \delta \mathbf{e}_{i_0}, \bar{\mathbf{a}}^a + \delta \mathbf{e}_{i_0}, \bar{\mathbf{a}}^o)$ is feasible to problem (16). Hence, $(g(\bar{\mathbf{a}}^r - \delta \mathbf{e}_{i_0}), g(\bar{\mathbf{a}}^a + \delta \mathbf{e}_{i_0}), g(-\bar{\mathbf{a}}^o)) <_{\text{lex}} (g(\bar{\mathbf{a}}^r), g(\bar{\mathbf{a}}^a), g(-\bar{\mathbf{a}}^o))$, which contradicts optimality of $(\bar{\mathbf{x}}, \bar{\mathbf{a}}^r, \bar{\mathbf{a}}^a, \bar{\mathbf{a}}^o)$ to the problem (16).

Thus $(\bar{\mathbf{x}}, \bar{\mathbf{a}}^o, \bar{\mathbf{a}}^a, \bar{\mathbf{a}}^r)$ fulfills formula (12) and therefore it is an optimal solution of the corresponding problem (17).

An important advantage of the RPM depends on its easy implementation as an expansion of the original multiple criteria model. Actually, even complicated component achievement functions of the form (7) are strictly increasing and concave, thus allowing for implementation of the entire RPM model (2) by an LP expansion [16].

The OWA aggregation is obviously a piecewise linear function since it remains linear within every area of the fixed order of arguments. The ordered achievements used in the OWA aggregation are, in general, difficult to implement due to the pointwise ordering. Its optimization can be implemented using the cumulated ordered achievements $\theta_k(\mathbf{a}) = \sum_{i=1}^k \theta_i(\mathbf{a})$ expressing respectively: the worst achievement, the total of the two worst achievements, the total of the three worst achievements, etc. Indeed,

$$\sum_{i=1}^m w_i \theta_i(\mathbf{a}) = \sum_{i=1}^m w'_i \bar{\theta}_i(\mathbf{a}) \quad (18)$$

where $w'_k = w_k - w_{k+1}$ for $k = 1, \dots, m-1$ and $w'_m = w_m$. This simplifies dramatically the optimization problem since quantities $\bar{\theta}_k(\mathbf{a})$ can be optimized without use of any integer variables [17]. First, let us notice that for any given vector \mathbf{a} , the cumulated ordered value $\theta_k(\mathbf{a})$ can be found as the optimal value of the following LP problem:

$$\begin{aligned} \bar{\theta}_k(\mathbf{a}) &= \max_{u_{ik}} \left\{ \sum_{i=1}^m a_i u_{ik} : \right. \\ &\quad \left. \sum_{i=1}^m u_{ik} = k, 0 \leq u_{ik} \leq 1 \quad \forall i \right\} \end{aligned} \quad (19)$$

The above problem is an LP for a given outcome vector \mathbf{a} while it becomes nonlinear for \mathbf{a} being a vector of variables. This difficulty can be overcome by taking advantage of the LP dual to (19). Introducing a dual variable t_k corresponding to the equation $\sum_{i=1}^m u_{ik} = k$, and variables d_{ik} corresponding to the upper bounds on u_{ik} , one gets the following LP dual of problem (19):

$$\begin{aligned} \bar{\theta}_k(\mathbf{a}) &= \min_{t_k, d_{ik}} \left\{ kt_k + \sum_{i=1}^m d_{ik} : \right. \\ &\quad \left. a_i \leq t_k + d_{ik}, d_{ik} \geq 0 \quad \forall i \right\} \end{aligned} \quad (20)$$

Due to the duality theory, for any given vector \mathbf{a} , the cumulated ordered coefficient $\bar{\theta}_k(\mathbf{a})$ can be found as the optimal value of the above LP problem. It follows from (20) that $\bar{\theta}_k(\mathbf{a}) = \max \{ kt_k + \sum_{i=1}^m (a_i - t_k)_+ \}$, where $(\cdot)_+$ denotes the nonnegative part of a number and t_k is an auxiliary (unbounded) variable. The latter, with the necessary adaptation to the location problems, is equivalent to the computational formulation of the k -centrum model introduced by [21]. Hence, formula (20) provides an alternative proof of that formulation.

Taking advantages of the LP expression (20) for $\bar{\theta}_k$, the entire OWA aggregation of the component achievement functions (10) can be expressed in terms of LP. This leads us to the following formulation of the OWA RPM problem (15):

$$\begin{aligned}
& \text{lex min} \left[\sum_{k=1}^m w'_k z_k^r, \sum_{k=1}^m w'_k z_k^a, \sum_{k=1}^m w'_k z_k^o \right] \\
& \text{s.t. } \mathbf{x} \in Q \\
& a_i = (f_i(\mathbf{x}) - r_i^r) / (r_i^a - r_i^r), \quad \forall i \in I \\
& a_i - a_i^o + a_i^a + a_i^r = 1, \quad \forall i \in I \\
& a_i^o \geq 0, \quad 0 \leq a_i^a \leq 1, \quad a_i^r \geq 0 \quad \forall i \in I \\
& z_k^r = kt_k^r + \sum_{i=1}^m d_{ik}^r, \quad \forall k \in I \\
& a_i^r \leq t_k^r + d_{ik}^r, \quad d_{ik}^r \geq 0 \quad \forall i, k \in I \\
& z_k^a = kt_k^a + \sum_{i=1}^m d_{ik}^a, \quad \forall k \in I \\
& a_i^a \leq t_k^a + d_{ik}^a, \quad d_{ik}^a \geq 0 \quad \forall i, k \in I \\
& z_k^o = kt_k^o + \sum_{i=1}^m d_{ik}^o, \quad \forall k \in I \\
& -a_i^o \leq t_k^o + d_{ik}^o, \quad d_{ik}^o \geq 0 \quad \forall i, k \in I
\end{aligned} \tag{21}$$

Note that the resulting formulation extends the original constraints and criteria with linear inequalities.

Theorem 7 *For any reference levels $r_i^a > r_i^r$, any positive strictly decreasing weights w_i , if $(\bar{\mathbf{x}}, \bar{\mathbf{a}}^r, \bar{\mathbf{a}}^a, \bar{\mathbf{a}}^o)$ is an optimal solution of the problem (21), then it is an optimal solution of the corresponding problem (13).*

Proof Let $(\bar{\mathbf{x}}, \bar{\mathbf{a}}^r, \bar{\mathbf{a}}^a, \bar{\mathbf{a}}^o)$ be an optimal solution of the problem (21) with weight vector \mathbf{w} . Following the OWA formulas (18) and (20), one may notice that, due to positive and strictly decreasing weights w_i , the problem (21) is equivalent to the following lexicographic optimization:

$$\text{lex min}_{\mathbf{a} \in A} (A_{\mathbf{w}}(\mathbf{a}^r), A_{\mathbf{w}}(\mathbf{a}^a), A_{\mathbf{w}}(-\mathbf{a}^o))$$

Further, following Lemma 1, due to strict monotonicity of the OWA aggregations with positive weights, the quadruple $(\bar{\mathbf{x}}, \bar{\mathbf{a}}^r, \bar{\mathbf{a}}^a, \bar{\mathbf{a}}^o)$ is also an optimal solution of the corresponding problem (13).

Corollary 1 *For any reference levels $r_i^a > r_i^r$, any positive strictly decreasing weights w_i , if $(\bar{\mathbf{a}}^r, \bar{\mathbf{a}}^a, \bar{\mathbf{a}}^o)$ is an optimal solution of the problem (21), then any decision vector $\bar{\mathbf{x}} \in Q$ generating this solution is an efficient solution of the corresponding MCO problem (1).*

Corollary 2 *If $\bar{\mathbf{x}}$ is an efficient solution of the MCO problem (1), then there exist aspiration levels $r_i^a = f_i(\bar{\mathbf{x}})$ such that the corresponding triple $(\bar{\mathbf{a}}^r, \bar{\mathbf{a}}^a, \bar{\mathbf{a}}^o)$ is an optimal solution of the corresponding problem (21), for any reservation levels $r_i^r < r_i^a$ and any positive strictly decreasing weights w_i .*

4 WOWA Enhancement

Typical RPM model allows weighting of several achievements only by straightforward rescaling of the achievement values [22]. The OWA RPM model enables one to introduce importance weights to affect achievement importance by rescaling accordingly its measure within the distribution of achievements as defined in the so-called Weighted OWA (WOWA) aggregation [23, 5]. Let $\mathbf{w} = (w_1, \dots, w_m)$ and $\mathbf{p} = (p_1, \dots, p_m)$ be weighting vectors of dimension m such that $w_i \geq 0$ and $p_i \geq 0$ for $i = 1, 2, \dots, m$ as well as $\sum_{i=1}^m p_i = 1$ (typically it is also assumed $\sum_{i=1}^m w_i = 1$, but it is not necessary in our applications). The corresponding Weighted OWA aggregation of outcomes $\mathbf{a} = (a_1, \dots, a_m)$ is defined as follows [23]:

$$A_{\mathbf{w}, \mathbf{p}}(\mathbf{a}) = \sum_{i=1}^m \omega_i \theta_i(\mathbf{a}) \tag{22}$$

where the weights ω_i are defined as

$$\omega_i = w^* \left(\sum_{k \leq i} p_{\tau(k)} \right) - w^* \left(\sum_{k < i} p_{\tau(k)} \right) \tag{23}$$

with w^* a monotone increasing function that interpolates points $(\frac{i}{m}, \sum_{k \leq i} w_k)$ together with the point $(0, 0)$ and τ representing the ordering permutation for \mathbf{a} (i.e. $a_{\tau(i)} = \theta_i(\mathbf{a})$). Moreover, function w^* is required to be a straight line when the point can be interpolated in this way, thus allowing the WOWA to cover the standard weighted mean with weights p_i as a special case of equal preference weights ($w_i = 1/m$ for $i = 1, 2, \dots, m$). Actually, for our purpose we use linear interpolation which obviously satisfies that requirement.

Example 1 Consider achievements vectors $\mathbf{a}' = (1, 2)$ and $\mathbf{a}'' = (2, 1)$. While introducing preferential weights $\mathbf{w} = (0.9, 0.1)$, one may calculate the OWA averages: $A_{\mathbf{w}}(\mathbf{y}') = A_{\mathbf{w}}(\mathbf{y}'') = 0.9 \cdot 2 + 0.1 \cdot 1 = 1.9$. Further, let us introduce importance weights $\mathbf{p} = (0.75, 0.25)$, which means that results under the first achievement are 3 times more important than those related to the second criterion. To take into account the importance weights in the WOWA aggregation (22) we introduce piecewise linear function

$$w^*(\xi) = \begin{cases} 0.9\xi/0.5 & \text{for } 0 \leq \xi \leq 0.5 \\ 0.9 + 0.1(\xi - 0.5)/0.5 & \text{for } 0.5 < \xi \leq 1.0 \end{cases}$$

and calculate weights ω_i according to the formula (23) as w^* increments corresponding to importance weights of the ordered outcomes, as illustrated in Fig. 4. In particular, one get $\omega_1 = w^*(p_2) = 0.45$ and $\omega_2 = 1 - w^*(p_2) = 0.55$ for vector \mathbf{a}' while $\omega_1 = w^*(p_1) = 0.95$ and $\omega_2 = 1 - w^*(p_1) = 0.05$ for vector \mathbf{a}'' . Finally, $A_{\mathbf{w}, \mathbf{p}}(\mathbf{a}') = 0.45 \cdot 2 + 0.55 \cdot 1 = 1.45$ and $A_{\mathbf{w}, \mathbf{p}}(\mathbf{a}'') =$

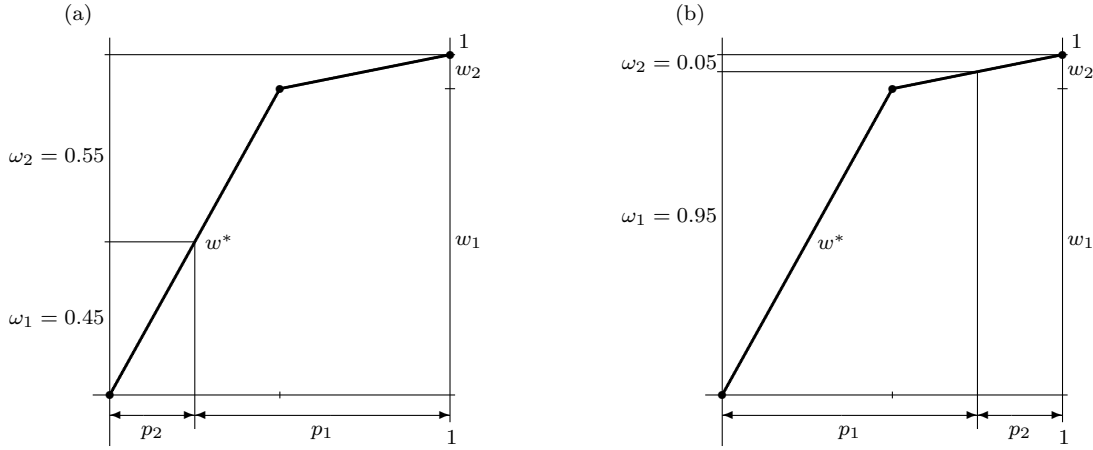

Fig. 4 Definition of weights ω_i for Example 1: (a) vector $\mathbf{a}' = (1, 2)$, (b) vector $\mathbf{a}'' = (2, 1)$

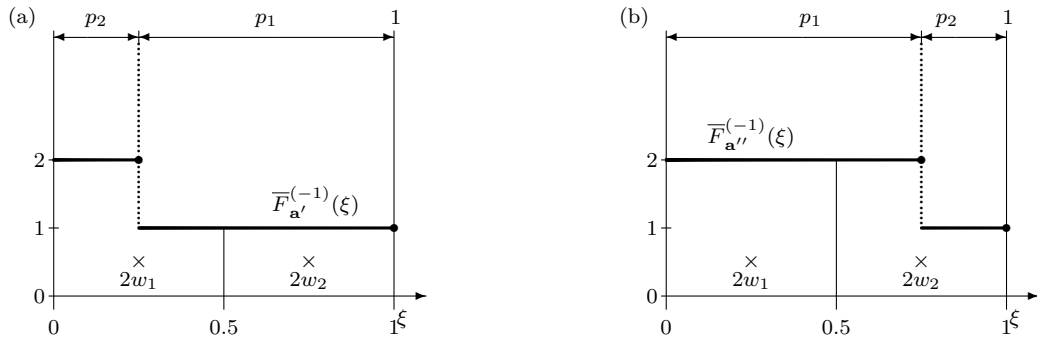

Fig. 5 Formula (24) applied to calculations in Example 1: (a) vector $\mathbf{a}' = (1, 2)$, (b) vector $\mathbf{a}'' = (2, 1)$

$0.95 \cdot 2 + 0.05 \cdot 1 = 1.95$. Note that one may alternatively compute the WOWA values by using the importance weights to replicate corresponding achievements and calculate then OWA aggregations. In the case of our importance weights $\mathbf{p} = (0.75, 0.25)$ we need to consider three copies of achievement a_1 and one copy of achievement a_2 thus generating vectors $\tilde{\mathbf{a}}' = (1, 1, 1, 2)$ and $\tilde{\mathbf{a}}'' = (2, 2, 2, 1)$ of four equally important achievements. Original preferential weights must be then applied respectively to the average of the two smallest outcomes and to the average of two largest outcomes. Indeed, we get $A_{\mathbf{w}, \mathbf{p}}(\mathbf{a}') = 0.9 \cdot 1.5 + 0.1 \cdot 1 = 1.45$ and $A_{\mathbf{w}, \mathbf{p}}(\mathbf{a}'') = 0.9 \cdot 2 + 0.1 \cdot 1.5 = 1.95$. We will further formalize this approach and take its advantages to build LP computational models.

The WOWA aggregation may be expressed with an alternative formula using directly preferential weights w_i as applied to the averages of corresponding portions of the ordered achievements (quantile intervals) according to the distribution defined by importance weights p_i [18–20]:

$$A_{\mathbf{w}, \mathbf{p}}(\mathbf{a}) = \sum_{i=1}^m w_i m \int_{\frac{i-1}{m}}^{\frac{i}{m}} \bar{F}_{\mathbf{a}}^{(-1)}(\xi) d\xi \quad (24)$$

where $\bar{F}_{\mathbf{y}}^{(-1)}$ is the stepwise function $\bar{F}_{\mathbf{y}}^{(-1)}(\xi) = \theta_i(\mathbf{y})$ for $\beta_{i-1} < \xi \leq \beta_i$. It can also be mathematically formalized as follows. First, we introduce the left-continuous right tail cumulative distribution function (cdf) defined as:

$$\bar{F}_{\mathbf{y}}(d) = \sum_{i \in I} p_i \delta_i(d) \quad \text{where } \delta_i(d) = \begin{cases} 1 & \text{if } y_i \geq d \\ 0 & \text{otherwise} \end{cases} \quad (25)$$

which for any real (outcome) value d provides the measure of outcomes greater or equal to d . Next, we introduce the quantile function $\bar{F}_{\mathbf{y}}^{(-1)}$ as the right-continuous inverse of the cumulative distribution function $\bar{F}_{\mathbf{y}}$:

$$\bar{F}_{\mathbf{y}}^{(-1)}(\xi) = \sup \{ \eta : \bar{F}_{\mathbf{y}}(\eta) \geq \xi \} \quad \text{for } 0 < \xi \leq 1.$$

Fig. 5 illustrates application of formula (24) to computations of the WOWA aggregations in Example 1. Note that $m = 2$, therefore the area below $\bar{F}_{\mathbf{a}'}^{(-1)}(\xi)$ within interval $[0, 0.5]$ is multiplied by $2w_1$ and added to the area below $\bar{F}_{\mathbf{a}'}^{(-1)}(\xi)$ within interval $[0.5, 1]$ multiplied by $2w_2$.

The formula (24) enables an easy proof of the strict monotonicity for the WOWA aggregation defined by positive weights. Indeed the following assertion is valid.

Lemma 2 For any positive weights \mathbf{w} and \mathbf{p} the WOWA aggregation $A_{\mathbf{w},\mathbf{p}}(\mathbf{a})$ is strictly increasing with respect to any component a_i .

Proof Let $\mathbf{a}' = \mathbf{a} + \varepsilon \mathbf{e}_{i_0}$ for some $i_0 \in I$ and $\varepsilon > 0$. Then [15] $\bar{F}_{\mathbf{a}'}^{(-1)}(\xi) \geq \bar{F}_{\mathbf{a}}^{(-1)}(\xi)$ for any $0 \leq \xi \leq 1$ and simultaneously $\int_0^1 \bar{F}_{\mathbf{a}'}^{(-1)}(\xi) d\xi = \sum_{i=1}^m p_i a'_i > \sum_{i=1}^m p_i a_i = \int_0^1 \bar{F}_{\mathbf{a}}^{(-1)}(\xi) d\xi$. Hence, following the formula (24), $A_{\mathbf{w},\mathbf{p}}(\mathbf{a}') > A_{\mathbf{w},\mathbf{p}}(\mathbf{a})$, which completes the proof.

Table 5 WOWA RPM selection with importance weights $\mathbf{p} = (\frac{4}{12}, \frac{3}{12}, \frac{2}{12}, \frac{1}{12}, \frac{1}{12}, \frac{1}{12})$

\mathbf{w}	S1	S2	S3	S4	S5	S6	S7
0.5	0.9	0.9	0.9	0.9	0.9	0.9	0.9
	0.9	0.9	0.9	0.9	0.9	0.2	0.9
0.25	0.9	0.9	0.9	0.0	0.0	0.2	0.9
	0.9	0.9	0.9	0.0	0.0	0.2	0.9
0.15	0.0	0.0	0.0	0.0	0.0	0.2	0.9
	0.0	0.0	0.0	0.0	0.0	0.2	0.9
0.05	0.0	0.0	0.0	0.0	0.0	0.2	0.9
	0.0	0.0	0.0	0.0	0.0	0.2	0.9
0.03	0.0	0.0	0.0	0.0	0.0	0.2	0.9
	0.0	0.0	0.0	0.0	0.0	0.2	0.6
0.02	0.0	0.0	0.0	0.0	0.0	0.2	0.2
	0.0	0.0	0.0	0.0	0.0	0.2	0.2
$A_{\mathbf{w},\mathbf{p}}(\mathbf{a}^a)$	0.74	0.68	0.56	0.45	0.45	0.38	0.88

Table 6 WOWA RPM selection with importance weights $\mathbf{p} = (\frac{1}{12}, \frac{1}{12}, \frac{1}{12}, \frac{1}{12}, \frac{1}{12}, \frac{7}{12})$

\mathbf{w}	S1	S2	S3	S4	S5	S6	S7
0.5	0.9	0.9	0.9	0.9	0.9	0.9	0.9
	0.9	0.9	0.9	0.9	0.9	0.9	0.9
0.25	0.9	0.9	0.9	0.9	0.9	0.9	0.9
	0.9	0.9	0.9	0.9	0.9	0.9	0.6
0.15	0.9	0.9	0.9	0.9	0.9	0.9	0.2
	0.9	0.9	0.9	0.9	0.9	0.9	0.2
0.05	0.9	0.9	0.9	0.9	0.9	0.9	0.2
	0.9	0.9	0.9	0.9	0.9	0.2	0.2
0.03	0.0	0.0	0.0	0.0	0.0	0.2	0.2
	0.0	0.0	0.0	0.0	0.0	0.2	0.2
0.02	0.0	0.0	0.0	0.0	0.0	0.2	0.2
	0.0	0.0	0.0	0.0	0.0	0.2	0.2
$A_{\mathbf{w},\mathbf{p}}(\mathbf{a}^a)$	0.86	0.86	0.86	0.86	0.86	0.85	0.69

The WOWA enhanced RPM can be based on the following lexicographic optimization problem [13]:

$$\text{lex min}_{\mathbf{a} \in A} (A_{\mathbf{w},\mathbf{p}}(\mathbf{a}^r), A_{\mathbf{w},\mathbf{p}}(\mathbf{a}^a), A_{\mathbf{w},\mathbf{p}}(-\mathbf{a}^o)) \quad (26)$$

used to generate current solutions according to the specified preferences. For instance, applying importance weighting $\mathbf{p} = (\frac{4}{12}, \frac{3}{12}, \frac{2}{12}, \frac{1}{12}, \frac{1}{12}, \frac{1}{12})$ to component achievements together with the OWA weights

\mathbf{w} from Table 4, one gets the WOWA aggregations from Table 5. The corresponding RPM method selects then solution S6, similarly to the case of equal importance weights. On the other hand, when increasing the importance of the last achievement with $\mathbf{p} = (\frac{1}{12}, \frac{1}{12}, \frac{1}{12}, \frac{1}{12}, \frac{1}{12}, \frac{7}{12})$, one gets the WOWA values from Table 6 suggesting the selection of solution S7.

The following assertions show that the WOWA RPM problem (26) always generates an efficient solution to the original MCO problem (Theorem 8) thus satisfying the property **P1**. Further, following Theorem 9, a solution reaching all the reservation levels is preferred to any solution failing to achieve at least one reservation level and according to Theorem 10, a solution reaching all the aspiration levels is preferred to any solution failing to achieve at least one aspiration level. Thus, the property **P2** is satisfied in terms of the ARBDS methodology.

Theorem 8 For any reference levels $r_i^a > r_i^r$, any positive weights \mathbf{w} and \mathbf{p} , if $(\bar{\mathbf{a}}^r, \bar{\mathbf{a}}^a, \bar{\mathbf{a}}^o)$ is an optimal solution of the problem (26), then any decision vector $\bar{\mathbf{x}} \in Q$ generating this solution is an efficient solution of the corresponding MCO problem (1).

Proof Let $\bar{\mathbf{x}}$ be a feasible vector generating $(\bar{\mathbf{a}}^r, \bar{\mathbf{a}}^a, \bar{\mathbf{a}}^o)$ optimal to the problem (26) with some positive weighting vectors \mathbf{w} and \mathbf{p} . Suppose that $\bar{\mathbf{x}}$ is not efficient to the MCO problem (1). This means, there exists a decision vector $\mathbf{x} \in Q$ such that $f_i(\mathbf{x}) \geq f_i(\bar{\mathbf{x}})$ for all $i \in I$ and $f_{i_0}(\mathbf{x}) > f_{i_0}(\bar{\mathbf{x}})$ for some outcome index $i_0 \in I$. Let us define a_i^r , a_i^a and a_i^o according to the formula (12). The triple $(\mathbf{a}^r, \mathbf{a}^a, \mathbf{a}^o)$ is then a feasible solution of the problem (26). Moreover, $a_i^r \leq \bar{a}_i^r$, $a_i^a \leq \bar{a}_i^a$ and $a_i^o \geq \bar{a}_i^o$ for all $i \in I$ where at least one of strict inequalities $a_{i_0}^r < \bar{a}_{i_0}^r$ or $a_{i_0}^a < \bar{a}_{i_0}^a$ or $a_{i_0}^o > \bar{a}_{i_0}^o$ holds. Hence, due to strict monotonicity of the WOWA aggregation with positive weighting vectors, one gets $A_{\mathbf{w},\mathbf{p}}(\mathbf{a}^r) \leq A_{\mathbf{w},\mathbf{p}}(\bar{\mathbf{a}}^r)$, $A_{\mathbf{w},\mathbf{p}}(\mathbf{a}^a) \leq A_{\mathbf{w},\mathbf{p}}(\bar{\mathbf{a}}^a)$ and $A_{\mathbf{w},\mathbf{p}}(-\mathbf{a}^o) \leq A_{\mathbf{w},\mathbf{p}}(-\bar{\mathbf{a}}^o)$ with at least one inequality strict. The latest assertion contradicts the lexicographic optimality of $(\bar{\mathbf{a}}^r, \bar{\mathbf{a}}^a, \bar{\mathbf{a}}^o)$ for the problem (26), which completes the proof.

Theorem 9 For any reference levels $r_i^a > r_i^r$, any positive weights \mathbf{w} and \mathbf{p} , if $(\bar{\mathbf{a}}^r, \bar{\mathbf{a}}^a, \bar{\mathbf{a}}^o)$ is an optimal solution of the problem (26), then all the reservation level underachievements \bar{a}_i^r are equal 0 whenever there exists a feasible solution $\mathbf{x} \in Q$ such that $f_i(\mathbf{x}) \geq r_i^r$ for all $i \in I$.

Proof Let $(\bar{\mathbf{a}}^r, \bar{\mathbf{a}}^a, \bar{\mathbf{a}}^o)$ be an optimal solution of the problem (26) with some positive weighting vectors \mathbf{w} and \mathbf{p} . Suppose that $\bar{a}_{i_0}^r < 0$ for some $i_0 \in I$ and there exists a feasible solution $\mathbf{x} \in Q$ such that $f_i(\mathbf{x}) \geq r_i^r$

for all $i \in I$. Let us define a_i^r , a_i^a and a_i^o according to the formula (12) and note that $a_i^r = 0$ for all $i \in I$. The triple $(\mathbf{a}^r, \mathbf{a}^a, \mathbf{a}^o)$ is then a feasible solution of the problem (26) and, due to positive weights, $A_{\mathbf{w}, \mathbf{p}}(\mathbf{a}^r) = 0 < A_{\mathbf{w}, \mathbf{p}}(\bar{\mathbf{a}}^r)$ thus contradicting the lexicographic optimality of $(\bar{\mathbf{a}}^r, \bar{\mathbf{a}}^a, \bar{\mathbf{a}}^o)$.

Theorem 10 *For any reference levels $r_i^a > r_i^r$, any positive weights \mathbf{w} and \mathbf{p} , if $(\bar{\mathbf{a}}^r, \bar{\mathbf{a}}^a, \bar{\mathbf{a}}^o)$ is an optimal solution of the problem (26), then all the aspiration level underachievements \bar{a}_i^a are equal 0 whenever there exists a feasible solution $\mathbf{x} \in Q$ such that $f_i(\mathbf{x}) \geq r_i^a$ for all $i \in I$.*

Proof Let $(\bar{\mathbf{a}}^r, \bar{\mathbf{a}}^a, \bar{\mathbf{a}}^o)$ be an optimal solution of the problem (26) with some positive weighting vectors \mathbf{w} and \mathbf{p} . Suppose that $\bar{a}_{i_0}^a < 0$ for some $i_0 \in I$ and there exists a feasible solution $\mathbf{x} \in Q$ such that $f_i(\mathbf{x}) \geq r_i^a$ for all $i \in I$. Let us define a_i^r , a_i^a and a_i^o according to the formula (12) and note that $a_i^r = a_i^r = 0$ for all $i \in I$. The triple $(\mathbf{a}^r, \mathbf{a}^a, \mathbf{a}^o)$ is then a feasible solution of the problem (26) and, due to positive weights, $A_{\mathbf{w}, \mathbf{p}}(\mathbf{a}^a) = 0 < A_{\mathbf{w}, \mathbf{p}}(\bar{\mathbf{a}}^a)$ thus contradicting the lexicographic optimality of $(\bar{\mathbf{a}}^r, \bar{\mathbf{a}}^a, \bar{\mathbf{a}}^o)$.

In order to show that the WOWA RPM model (26) provides us with a complete parameterization of the efficient set, we will prove in the following theorem that for each efficient solution $\bar{\mathbf{x}}$ there exist aspiration and reservation vectors for which $\bar{\mathbf{x}}$ with the corresponding values of the multilevel achievements is an optimal solution of the problem (26).

Theorem 11 *If $\bar{\mathbf{x}}$ is an efficient solution of the MCO problem (1), then there exist aspirations levels r_i^a such that the corresponding triple $(\bar{\mathbf{a}}^r, \bar{\mathbf{a}}^a, \bar{\mathbf{a}}^o)$ is an optimal solution of the problem (26), for any reservation levels $r_i^r < r_i^a$ and positive weighting vectors \mathbf{w} and \mathbf{p} .*

Proof Let us set the aspiration levels as $r_i^a = f_i(\bar{\mathbf{x}})$ for $i \in I$. For any reservation levels $r_i^r < r_i^a$, all the corresponding multilevel achievements defined according to the formula (12) take the zero values: $\bar{\mathbf{a}}^r = 0$, $\bar{\mathbf{a}}^a = 0$ and $\bar{\mathbf{a}}^o = 0$. Suppose that for some weights the triple $(0, 0, 0)$ is not an optimal solution of the corresponding problem (26). This means there exists a vector $\mathbf{x} \in Q$ such that $\mathbf{a}^r = 0$, $\mathbf{a}^a = 0$, $\mathbf{a}^o \geq 0$ and $A_{\mathbf{w}, \mathbf{p}}(-\mathbf{a}^o) < A_{\mathbf{w}, \mathbf{p}}(-\bar{\mathbf{a}}^o)$. Hence, $f_i(\mathbf{x}) \geq f_i(\bar{\mathbf{x}}) \forall i \in I$ and $f_{i_o}(\mathbf{x}) > f_{i_o}(\bar{\mathbf{x}})$ for some index $i_o \in I$. The latest assertion contradicts the efficiency of $\bar{\mathbf{x}}$ to (1), which completes the proof.

In the proof of Theorem 11 we have used one set of preferential parameters leading to the given efficient solution. Obviously, there are many alternative settings of

the parameters allowing to reach this goal. For instance, one may set the reservation levels as $r_i^r = f_i(\bar{\mathbf{x}})$ for $i \in I$ while taking any aspiration levels $r_i^a > r_i^r$.

According to the original definition, the WOWA operator is a quite complicated function of the aggregated outcomes. Nevertheless, similar to the OWA RPM model (21), the WOWA RPM optimization can be simply implemented as an LP expansion of the original MCO problem. Recall that the formula (24) defines the WOWA operator applying the preferential weights w_i to importance weighted averages within quantile intervals. It may be reformulated using the tail averages [18–20]:

$$A_{\mathbf{w}, \mathbf{p}}(\mathbf{a}) = \sum_{k=1}^m w'_k m L(\mathbf{a}, \mathbf{p}, \frac{k}{m}) \quad (27)$$

where weights $w'_k = w_k - w_{k+1}$ for $k = 1, \dots, m-1$ and $w'_m = w_m$, and $L(\mathbf{y}, \mathbf{p}, \xi)$ is defined by left-tail integrating of $\bar{F}_{\mathbf{y}}^{(-1)}$, i.e.

$$L(\mathbf{y}, \mathbf{p}, \xi) = \int_0^\xi \bar{F}_{\mathbf{y}}^{(-1)}(\alpha) d\alpha \quad (28)$$

Values $L(\mathbf{a}, \mathbf{p}, \xi)$ for any $0 \leq \xi \leq 1$ can be given by optimization:

$$L(\mathbf{a}, \mathbf{p}, \xi) = \max_{\pi_i} \left\{ \sum_{i=1}^m a_i \pi_i : \sum_{i=1}^m \pi_i = \xi, \right. \\ \left. 0 \leq \pi_i \leq p_i \quad \forall i \in I \right\} \quad (29)$$

Introducing a dual variable t corresponding to the equation $\sum_{i=1}^m \pi_i = \xi$, and variables d_i corresponding to the upper bounds on π_i , one gets the following LP dual expression for $L(\mathbf{a}, \mathbf{p}, \xi)$

$$L(\mathbf{a}, \mathbf{p}, \xi) = \min_{t, d_i} \left\{ \xi t + \sum_{i=1}^m p_i d_i : \right. \\ \left. t + d_i \geq a_i, d_i \geq 0 \quad \forall i \in I \right\} \quad (30)$$

According to (27) and (30) one gets finally the following model for the WOWA RPM:

$$\text{lex min} \left[\sum_{k=1}^m w'_k z_k^r, \sum_{k=1}^m w'_k z_k^a, \sum_{k=1}^m w'_k z_k^o \right] \\ \text{s.t. } \mathbf{x} \in Q \\ a_i = (f_i(\mathbf{x}) - r_i^r) / (r_i^a - r_i^r), \quad \forall i \in I \\ a_i - a_i^o + a_i^a + a_i^r = 1, \quad \forall i \in I \\ a_i^o \geq 0, \quad 0 \leq a_i^a \leq 1, \quad a_i^r \geq 0 \quad \forall i \in I \\ z_k^r = kt_k^r + m \sum_{i=1}^m p_i d_{ik}^r, \quad \forall k \in I \\ a_i^r \leq t_k^r + d_{ik}^r, \quad d_{ik}^r \geq 0 \quad \forall i, k \in I \\ z_k^a = kt_k^a + m \sum_{i=1}^m p_i d_{ik}^a, \quad \forall k \in I \\ a_i^a \leq t_k^a + d_{ik}^a, \quad d_{ik}^a \geq 0 \quad \forall i, k \in I \\ z_k^o = kt_k^o + m \sum_{i=1}^m p_i d_{ik}^o, \quad \forall k \in I \\ -a_i^o \leq t_k^o + d_{ik}^o, \quad d_{ik}^o \geq 0 \quad \forall i, k \in I \quad (31)$$

Table 7 Criteria and their attributes for the sample billing system selection

	f_1 Relia- bility	f_2 Effi- ciency	f_3 Invest. cost	f_4 Install. time	f_5 Oprnl. cost	f_6 Warranty period
Units	1–10	CAPS	mln. EUR	months	mln. EUR	years
Optimization	max	max	min	min	min	max
Reservation	8	50	2	12	1.25	0.5
Aspiration	10	200	0	6	0.5	2
Importance weights	3	3	1	1	1	3

Table 8 Criteria values y_i and individual achievements a_i for five billing systems

i	System A		System B		System C		System D		System E	
	y_i	a_i	y_i	a_i	y_i	a_i	y_i	a_i	y_i	a_i
1	10	1.00	9	0.50	10	1.00	9	0.50	10	1.00
2	200	1.00	100	0.33	170	0.80	90	0.27	150	0.67
3	1	0.50	0.3	0.85	0.8	0.60	0.2	0.90	0.5	0.75
4	8	0.67	3	1.50	8	0.67	8	0.67	5	1.20
5	1	0.33	1	0.33	0.6	0.87	0.2	1.40	1	0.33
6	2	1.00	2	1.00	1	0.33	2	1.00	1.5	0.67

thus allowing for implementation as an LP expansion of the original problem. The following theorem justifies the model (31) as an implementation of the WOWA RPM approach (26) thus preserving its preference model properties.

Theorem 12 *For any reference levels $r_i^a > r_i^r$, any positive importance weights p_i and positive strictly decreasing weights w_i , if $(\bar{\mathbf{x}}, \bar{\mathbf{a}}^r, \bar{\mathbf{a}}^a, \bar{\mathbf{a}}^o)$ is an optimal solution of the problem (31), then it is an optimal solution of the corresponding problem (26).*

Proof Let $(\bar{\mathbf{x}}, \bar{\mathbf{a}}^r, \bar{\mathbf{a}}^a, \bar{\mathbf{a}}^o)$ be an optimal solution of the problem (31) with some positive weighting vectors \mathbf{w} and \mathbf{p} . Following the WOWA formulas (27) and (30) one may notice that the problem (31) is equivalent to the following lexicographic optimization:

$$\text{lex min}_{\mathbf{a} \in A} (A_{\mathbf{w}, \mathbf{p}}(\mathbf{a}^r), A_{\mathbf{w}, \mathbf{p}}(\mathbf{a}^a), A_{\mathbf{w}, \mathbf{p}}(-\mathbf{a}^o))$$

Further, following Lemmas 1 and 2, the quadruple $(\bar{\mathbf{x}}, \bar{\mathbf{a}}^r, \bar{\mathbf{a}}^a, \bar{\mathbf{a}}^o)$ is also an optimal solution of the corresponding problem (26).

Corollary 3 *For any reference levels $r_i^a > r_i^r$, any positive importance weights p_i and positive strictly decreasing preferential weights w_i , if $(\bar{\mathbf{a}}^r, \bar{\mathbf{a}}^a, \bar{\mathbf{a}}^o)$ is an optimal solution of the problem (31), then any decision vector $\bar{\mathbf{x}} \in Q$ generating this solution is an efficient solution of the corresponding MCO problem (1).*

Corollary 4 *If $\bar{\mathbf{x}}$ is an efficient solution of the MCO problem (1), then there exist aspirations levels $r_i^a = f_i(\bar{\mathbf{x}})$ such that the corresponding triple $(\bar{\mathbf{a}}^r, \bar{\mathbf{a}}^a, \bar{\mathbf{a}}^o)$ is an optimal solution of the corresponding problem (31),*

for any reservation levels $r_i^r < r_i^a$, any positive importance weights p_i and positive strictly decreasing preferential weights w_i .

5 Illustrative Example

In order to illustrate the WOWA RPM performances let us analyze a simplified multicriteria problem of information system selection. We consider a billing system selection for a telecommunication company. The decision is based on 6 criteria related to the system reliability, processing efficiency, investment costs, installation time, operational costs, and warranty period. All these attributes may be viewed as criteria, either maximized or minimized. Table 7 presents all the criteria with their measurement units and optimization directions. There are also specified the aspiration and reservation levels for each criterion as well as the importance factors (not normalized to weights p_i) for several achievements. The importance factors emphasize achievements related to the quality of the system. Five candidate billing systems have been accepted for the final selection procedure. All they meet the minimal requirements defined by the reservation levels. Table 8 presents for all the systems (columns) their criteria values y_i and the corresponding linear achievement values a_i computed according to the formula (11). Exactly, the formula (11) is directly applied to the maximized outcomes while its symmetric adaptation is applied to the minimized ones.

Table 9 presents for all the systems (columns) their aspiration underachievements values \mathbf{a}^a ordered from the worst to the best taking into account replications

Table 9 WOWA RPM selection with criteria importance factors (3, 3, 1, 1, 1, 3)

\mathbf{w}	A	B	C	D	E
0.6	0.67	0.67	0.67	0.73	0.67
	0.50	0.67	0.67	0.73	0.33
0.2	0.33	0.67	0.67	0.73	0.33
	0.00	0.67	0.40	0.50	0.33
0.1	0.00	0.50	0.33	0.50	0.33
	0.00	0.50	0.30	0.50	0.33
0.05	0.00	0.50	0.30	0.33	0.33
	0.00	0.15	0.30	0.10	0.25
0.03	0.00	0.00	0.13	0.00	0.00
	0.00	0.00	0.00	0.00	0.00
0.02	0.00	0.00	0.00	0.00	0.00
	0.00	0.00	0.00	0.00	0.00
$A_{\mathbf{w},\mathbf{p}}(\mathbf{a}^a)$	0.414	0.602	0.556	0.622	0.455

according to the importance weights allowing for easy WOWA aggregation computations following the formula (24). One may notice that except of system D all the other systems have the same worst achievement value $\max_i a_i^a = 0.67$. Selection among systems A, B, C and E depends only on the regularization of achievements aggregation used in the RPM approach. The WOWA RPM method taking into account the importance weights together with the preferential weights $\mathbf{w} = (0.6, 0.2, 0.1, 0.05, 0.03, 0.02)$ points out system A as the best one.

Table 10 WOWA RPM selection with criteria importance factors (3, 3, 1, 1, 1, 3) and modified reference levels

\mathbf{w}	A	B	C	D	E
0.6	1.00	1.00	0.67	0.73	1.00
	0.50	0.67	0.67	0.73	0.33
0.2	0.33	0.67	0.67	0.73	0.33
	0.00	0.67	0.50	0.50	0.33
0.1	0.00	0.50	0.40	0.50	0.33
	0.00	0.50	0.33	0.50	0.33
0.05	0.00	0.50	0.30	0.33	0.33
	0.00	0.15	0.30	0.10	0.25
0.03	0.00	0.00	0.30	0.00	0.00
	0.00	0.00	0.00	0.00	0.00
0.02	0.00	0.00	0.00	0.00	0.00
	0.00	0.00	0.00	0.00	0.00
$A_{\mathbf{w},\mathbf{p}}(\mathbf{a}^a)$	0.483	0.612	0.630	0.622	0.465

System A, similar to B and D, is characterized by the highest operational cost. In order to improve the operational cost one may try to strengthen the requirements given by the corresponding reference levels. Let us put $r_5^g = 0.2$ and $r_5^r = 1.0$. Still there are no positive reservation underachievements and the selection is based on the aspiration underachievements. Table 10 presents for all the systems their aspiration underachievements values ordered from the worst to

the best with replications according to the importance weights of the WOWA formula (24). One may notice that now system E is pointed out as the best meeting requirements, actually not much better than system A. Both these systems have the worst value of the operational cost. Systems C and D characterized by lower (better) values of the operational cost are evaluated as much worse. Indeed, to increase importance of the operational cost criterion we should rather increase its importance weight. For instance, when instead of changing the reference levels we increase the importance of criterion f_5 to 3 and simultaneously decrease importance of criterion f_6 to 1, we get the results presented in Table 11. System C with relatively low (but not the lowest) operational cost is then pointed out as the best one.

Table 11 WOWA RPM selection with criteria importance factors (3, 3, 1, 1, 3, 1)

\mathbf{w}	A	B	C	D	E
0.6	0.67	0.67	0.67	0.73	0.67
	0.67	0.67	0.40	0.73	0.67
0.2	0.67	0.67	0.33	0.73	0.67
	0.50	0.67	0.20	0.50	0.33
0.1	0.33	0.67	0.20	0.50	0.33
	0.00	0.67	0.20	0.50	0.33
0.05	0.00	0.50	0.13	0.33	0.33
	0.00	0.50	0.13	0.10	0.25
0.03	0.00	0.50	0.13	0.00	0.00
	0.00	0.15	0.00	0.00	0.00
0.02	0.00	0.00	0.00	0.00	0.00
	0.00	0.00	0.00	0.00	0.00
$A_{\mathbf{w},\mathbf{p}}(\mathbf{a}^a)$	0.536	0.636	0.401	0.622	0.550

On the other hand, when we increase strongly the importance of criterion f_5 to 5 and simultaneously decrease importance of criteria f_1 and f_2 to 1 while leaving the importance of f_6 on the level 3 we get the results presented in Table 12. System D with the lowest operational cost is then selected indeed.

In order to provide a lucid illustration we have considered an example of discrete choice problem with a few explicitly given alternatives where any complicated aggregation method can be applied. However, the WOWA RPM model is able to solve MCO problems with infinite number of decision alternatives implicitly given by constraints of the feasible set.

Conclusions

The reference point method is a very convenient technique for interactive analysis of the multiple criteria optimization problems. It provides the DM with a tool for

Table 12 WOWA RPM selection with criteria importance factors (1, 1, 1, 1, 5, 3)

w	A	B	C	D	E
0.6	0.67	0.67	0.67	0.73	0.67
	0.67	0.67	0.67	0.50	0.67
0.2	0.67	0.67	0.67	0.33	0.67
	0.67	0.67	0.40	0.10	0.67
0.1	0.67	0.67	0.33	0.00	0.67
	0.50	0.67	0.20	0.00	0.33
0.05	0.33	0.50	0.13	0.00	0.33
	0.00	0.15	0.13	0.00	0.33
0.03	0.00	0.00	0.13	0.00	0.33
	0.00	0.00	0.13	0.00	0.25
0.02	0.00	0.00	0.13	0.00	0.00
	0.00	0.00	0.00	0.00	0.00
$A_{w,p}(a^a)$	0.603	0.619	0.546	0.412	0.611

an open analysis of the efficient frontier. The interactive analysis is navigated with the commonly accepted control parameters expressing reference levels for the individual objective functions. The component achievement functions quantify the DM satisfaction from the individual outcomes with respect to the given reference levels. The final scalarizing function is built as the augmented max-min aggregation of component achievements, which means that the worst individual achievement is essentially maximized, but the optimization process is additionally regularized with the term representing the average achievement. The regularization by the average achievement is easily implementable but it may disturb the basic max-min aggregation. In order to avoid inconsistencies caused by the regularization, the max-min solution may be regularized by taking into account also the second worst achievement, the third worse and so on, thus resulting in much better modeling of the reference levels concept [3].

The OWA aggregation with monotonic weights combines all the component achievements allocating the largest weight to the worst achievement, the second largest weight to the second worst achievement, the third largest weight to the third worst achievement, and so on. Further, following the concept of Weighted OWA [23], the importance weighting of several achievements may be incorporated into the RPM. Such a WOWA enhancement of the RPM uses importance weights to affect achievement importance by rescaling accordingly its measure within the distribution of achievements rather than straightforward rescaling of achievement values [22]. The ordered regularizations are more complicated in implementation due to the requirement of pointwise ordering of component achievements. However, the recent progress in optimization methods for ordered averages [17] allows one to implement the OWA RPM quite effectively by taking advantages of piece-

wise linear expression of the cumulated ordered achievements. A similar computational model can be achieved for the WOWA RPM. Actually, the resulting formulation extends the original constraints and criteria with simple linear inequalities thus allowing for a quite efficient implementation.

Acknowledgements

The research was partially supported by the Polish Ministry of Science and Higher Education under the research grant N N516 4307 33.

References

1. Granat J, Makowski M (2000) ISAAP – Interactive Specification and Analysis of Aspiration-Based Preferences. *Eur J Opnl Res* 122:469–485.
2. Kostreva MM, Ogryczak W (1999) Linear optimization with multiple equitable criteria. *RAIRO Oper Res* 33:275–297.
3. Kostreva MM, Ogryczak W, Wierzbicki A (2004) Equitable aggregations and multiple criteria analysis. *Eur J Opnl Res* 158:362–367.
4. Lewandowski A, Wierzbicki AP (1989) *Aspiration Based Decision Support Systems – Theory, Software and Applications*. Springer, Berlin.
5. Liu X (2006) Some properties of the weighted OWA operator. *IEEE Trans Sys Man Cyber B* 368:118–127.
6. Llamazares B (2004) Simple and absolute special majorities generated by OWA operators. *Eur J Opnl Res* 158:707–720.
7. Malczewski J, Ogryczak W (1990) An interactive approach to the central facility location problem: locating pediatric hospitals in Warsaw. *Geograph Anal* 22:244–258.
8. Malczewski J, Ogryczak W (1996) Multiple criteria location problem: 2. Preference-based techniques and interactive decision support. *Env Planning A* 28:69–98.
9. Miettinen K, Mäkelä MM (2002) On scalarizing functions in multiobjective optimization. *OR Spectrum* 24:193–213.
10. Ogryczak W (1994) A goal programming model of the reference point method. *Ann Opns Res* 51:33–44.
11. Ogryczak W (1997) Preemptive reference point method. In: Climaco J (ed). *Multicriteria Analysis – Proceedings of the XIth International Conference on MCDM*. Springer, Berlin, pp 156–167.
12. Ogryczak W (2001) On goal programming formulations of the reference point method. *J Opnl Res Soc* 52:691–698.
13. Ogryczak W (2008) WOWA enhancement of the preference modeling in the Reference Point Method. In: *MDAI 2008, LNAI vol 5285*, pp 38–49.
14. Ogryczak W, Lahoda S (1992) Aspiration/reservation based decision support – A step beyond goal programming. *J MCDA* 1:101–117.
15. Ogryczak W, Ruszczyński A (2002) Dual stochastic dominance and related mean-risk models. *SIAM J Optimization* 13:60–78.
16. Ogryczak W, Studziński K, Zorychta K (1992) DINAS: A Computer-Assisted Analysis System for Multiobjective Transshipment Problems with Facility Location. *Comp Opns Res* 19:637–647.
17. Ogryczak W, Śliwiński T (2003) On solving linear programs with the ordered weighted averaging objective. *Eur J Opnl Res*, 148:80–91.

18. Ogryczak W, Śliwiński T (2007) On Optimization of the importance weighted OWA aggregation of multiple criteria. In ICCSA 2007, LNCS, vol 4705, pp 804–817.
19. Ogryczak W, Śliwiński T (2007) On decision support under risk by the WOWA optimization. In ECSQARU 2007, LNAI, vol 4724, pp 779–790.
20. Ogryczak W, Śliwiński T (2009) On Efficient WOWA Optimization for Decision Support under Risk, *Intl J Approx Reason*, forthcoming, doi:10.1016/j.ijar.2009.02.010.
21. Ogryczak W, Tamir A (2003) Minimizing the sum of the k largest functions in linear time. *Inform Proc Let* 85:117–122.
22. Ruiz F, Luque M, Cabello JM (2009) A classification of the weighting schemes in reference point procedures for multiobjective programming. *J Opnl Res Soc*, 60:544–553.
23. Torra V (1997) The weighted OWA operator. *Int J Intell Syst* 12:153–166.
24. Torra V, Narukawa Y (2007) *Modeling Decisions Information Fusion and Aggregation Operators*. Springer, Berlin.
25. Wierzbicki AP (1982) A mathematical basis for satisficing decision making. *Math Modelling* 3:391–405.
26. Wierzbicki AP (1986) On completeness and constructiveness of parametric characterizations to vector optimization problems. *OR Spektrum* 8:73–87.
27. Wierzbicki AP, Makowski M, Wessels J (2000) *Model Based Decision Support Methodology with Environmental Applications*. Kluwer, Dordrecht.
28. Yager RR (1988) On ordered weighted averaging aggregation operators in multicriteria decision making. *IEEE Trans Sys Man Cyber* 18:183–190.
29. Yager RR (1997) On the analytic representation of the Leximin ordering and its application to flexible constraint propagation. *Eur J Opnl Res* 102:176–192.
30. Zimmermann H.-J. (1996) *Fuzzy Sets Theory and Its Applications*. Kluwer, Dordrecht.